

**Series 500
Marine Transmission
Service Manual**



**BorgWarner
Marine & Industrial Transmissions**

Velvet Drive®
BY BORG-WARNER®

MARINE TRANSMISSIONS

Contents

Section		Page
1	INTRODUCTION AND DESCRIPTION	
	1-1. Introduction	1-1
	1-8. Description	1-2
2	IN-BOAT SERVICE AND TROUBLESHOOTING	
	2-1. Maintenance	2-1
	2-9. Troubleshooting	2-2
	2-12. Removal and Installation	2-3
3	DISASSEMBLY	
	3-1. General Information	3-1
	3-4. Removal and Installation of Transmission	3-1
	3-6. Transmission Disassembly	3-1
4	CLEANING, INSPECTION, REPAIR OR REPLACEMENT	
	4-1. Cleaning	4-1
	4-5. Inspection	4-1
	4-10. Parts Replacement	4-4
5	ASSEMBLY	
	5-1. General Information	5-1
	5-4. Transmission Assembly	5-1
P	PARTS	P-1
T	SPECIAL TOOLS	T-1

Section 1

Introduction and Description

1-1. INTRODUCTION

1-2. **PURPOSE.** This manual contains maintenance, service and parts information for the Series 500 Velvet Drive® Marine Transmission (see figure 1-1) manufactured by Borg-Warner Marine and Industrial Transmissions, P.O. Box 2688, Muncie, IN 47307.

1-3. **SCOPE.** As you will see in the Table of Contents, this manual provides information for maintenance, troubleshooting, removal, disassembly, cleaning, inspection, repair or replacement, assembly and installation of the transmission.

1-4. Section P of the manual contains an illustrated parts list. The arrangement of the exploded view illustrations is described in the introduction to Section P. Each detail part shown in the exploded views is assigned an index number. This same index number is used to identify the part throughout this manual. For example, index number 67 (in parentheses in the text) refers to the output shaft regardless of the manual section or the specific transmission being serviced.

1-5. The exploded view illustrations in Section P make it possible to view the complete assembly in addition to the illustrations in the service sections relating to a specific service procedure.

1-6. Section T lists special tools. These tools, or equivalent are required for proper disassembly and assembly of the transmission.

1-7. **ABBREVIATIONS.** Abbreviations, other than those in common use, found in this manual are identified in Table 1-1.

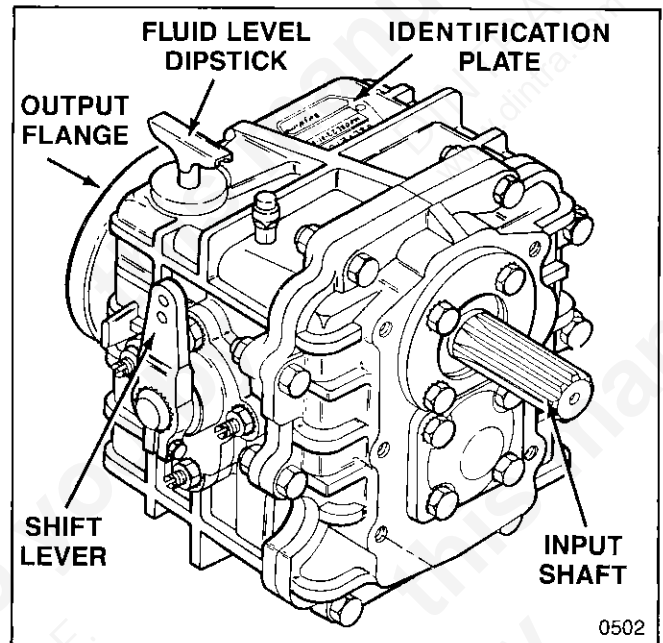

Figure 1-1. 500 Series Marine Transmission

Table 1-1. Abbreviations

AR	As Required
Assy	Assembly
ID	Inside Diameter
OD	Outside Diameter
PN	Part Number
Qty or QY	Quantity
Ref	Reference

1-8. DESCRIPTION

1-9. GENERAL DESCRIPTION. The Borg-Warner Series 500 Velvet Drive® is a single-speed, forward/reverse, mechanical-shift transmission. Forward gear ratio varies from model to model and is listed in Table 1-2. Reverse ratio is 1.80:1 for all models. The input and output shafts are supported by tapered roller bearings. The output and reverse gears rotate on needle bearings on the output shaft when not engaged. Helical gearing is used throughout. The transmission has separate, multi-disc, forward and reverse clutches.

1-10. DESCRIPTION OF OPERATION. The one-piece input shaft has two gears (see figure 1-2). One gear drives the output gear directly. The other input shaft gear drives the reverse gear through an idler gear. Thus, with the transmission in neutral, the output and reverse gears rotate in opposite directions on

the stationary output shaft on needle bearings. When the shift lever is moved to the aft position, the shift fork moves the shift collar on the output shaft to engage the forward clutch. Then, the output gear drives the shift collar which is keyed to the output shaft through a series of channels filled with steel balls. This turns the output shaft and propeller shaft to produce forward boat motion. When the shift lever is returned to the neutral position, the output gear clutch releases and output shaft rotation stops. When the shift lever is moved to the opposite position, the shift fork moves the shift collar to engage the reverse gear clutch. This results in output shaft rotation that moves the boat backward.

1-11. APPLICATION. The Series 500 marine transmission is used with lower horsepower diesel engines on sailboats, canal boats, small cruisers and work boats, and other such craft.

Table 1-2. General Specifications

ASSEMBLY NO.	RATIO	FLUID CAPACITY* QTS/LITERS	DRY WEIGHT LBS/KGS
2301-000-001	1.48:1	.45/.43	27/12.2
2301-000-002	2.05:1	.45/.43	27/12.2
2301-000-003	2.53:1	.45/.43	27/12.2
2301-000-004	2.94:1	.45/.43	27/12.2

*Approximate, depending on angle of transmission installation.

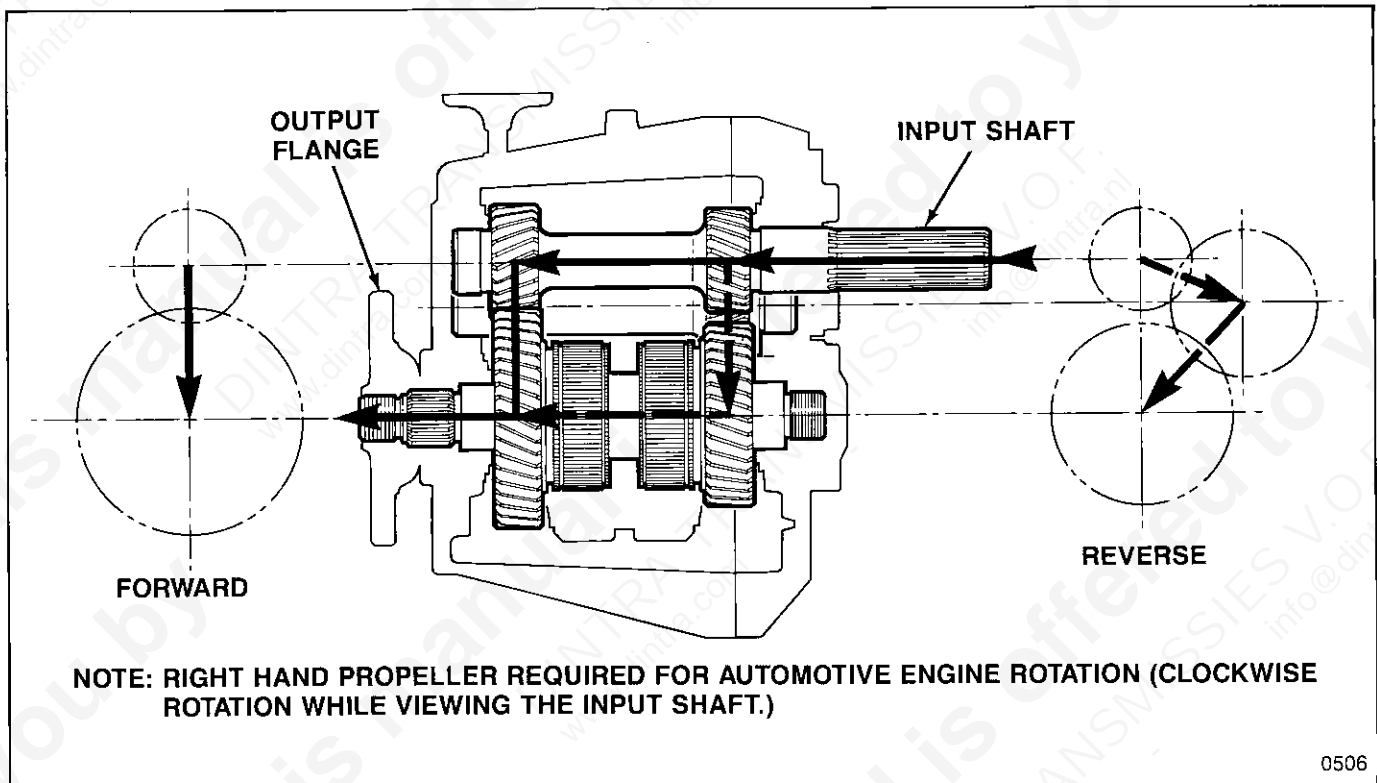

Figure 1-2. Series 500 Transmission Operation

Section 2

In-Boat Service and Troubleshooting

2-1. MAINTENANCE

2-2. GENERAL. The periodic maintenance required for the Borg-Warner Series 500 marine transmission is given in Table 2-1. Follow this schedule to ensure trouble-free operation and long service life.

2-3. LUBRICATION SCHEDULE. Refer to Table 2-1.

 **CAUTION:** Temperatures in excess of 220°F (104°C) will break down the transmission fluid. If there are signs of burnt fluid or there is other reason to believe that the transmission has overheated, change the fluid immediately.

2-4. APPROVED TRANSMISSION FLUID. Dexron II, Type F, or any transmission fluid which meets Detroit Diesel Allison C3 or Caterpillar TO-11 specification is recommended. Do not mix different brands or types of transmission fluid.

2-5. CHECKING TRANSMISSION FLUID LEVEL. The transmission should be at operating temperature to get an accurate fluid level reading. The fluid will expand when heated and significantly affect the level in the transmission (see maximum fluid temperature CAUTION above). Any additions to the boat that will change the installed angle of the transmission at rest may require an oil level adjustment.

 **WARNING:** Hot transmission fluid can cause burns.

 **WARNING:** Do not enter the engine compartment with the engine running.

Table 2-1. Scheduled Maintenance

MAINTENANCE	INTERVAL		
	BEFORE OPERATING BOAT	MONTHLY OR 100 HR	ANNUALLY OR 1000 HR
Check transmission fluid level. Add fluid to proper level if required (refer to paragraph 2-5).	X		
Remove dipstick and check transmission fluid for signs of water or other contaminants. Smell for signs of burnt (overheated) fluid. If noted, change fluid (refer to paragraph 2-8).	X		
Change transmission fluid (refer to paragraph 2-8).			X
Check control linkage and shift lever for proper operation. No sticking binding or looseness is permitted. Check control cable for full travel.		X	
Check cooler (if used) lines and connections for leakage or damage. Connections must be tight.		X	X
Check transmission for signs of fluid leakage. Torque transmission bolts to specifications (refer to Section 5).		X	X
Check that breather,(69), figure 2-1) is open and that cap moves freely. Replace breather if clogged.		X	
Check that transmission and adapter or bell housing mounting bolts are tight. Torque to specifications (refer to paragraph 2-15).			X

2-6. WARM FLUID LEVEL CHECK. With the engine at operating temperature, place the shift lever in neutral and shut down the engine. Remove the dipstick and wipe it clean. Insert the clean dipstick fully into the transmission, withdraw, and read the fluid level. Add or remove fluid as necessary to bring the fluid level to the full mark on the dipstick.

2-7. COLD FLUID LEVEL CHECK. For ease of checking the fluid level prior to start-up, a cold fluid level mark can be made on the dipstick. First, make the warm fluid level check as described above and adjust the fluid level to the dipstick full mark. Shut down the engine and allow the transmission to cool overnight. With the transmission cold, check the fluid level as described above and put a cold full mark on the dipstick.

2-8. CHANGING TRANSMISSION FLUID. A seasonal change of the transmission fluid is required for all pleasure boats. Work boats require transmission fluid change every 1000 hours. In addition, the transmission fluid must be changed anytime it becomes overheated, contaminated, changes color, or becomes rancid smelling.



WARNING: Do not use gasoline or any other volatile or highly combustible liquid as a cleaning solvent when changing the transmission fluid.

1. Remove the dipstick (see figure 2-1).
2. Use a suction pump through the dipstick opening to remove fluid from the transmission.
3. Fill the transmission with the proper type (refer to paragraph 2-4) of transmission fluid.
4. Replace dipstick and check fluid level (refer to paragraph 2-5).

2-9. TROUBLESHOOTING

2-10. GENERAL. In the event of operating difficulty, it is recommended that the transmission (engine) be shut down. If the problem is within the transmission, it may be necessary to remove and disassemble the transmission to accurately pinpoint the source of trouble. Specific inspection procedures for detail parts of the transmission are provided in Section 4.

2-11. TROUBLESHOOTING CHART. Table 2-2 lists troubles which may be encountered along with possible causes and corrections.

Table 2-2. Trouble Analysis Chart

PROBLEM	PROBABLE CAUSE	CORRECTION
No forward or reverse	Damaged shift linkage	Repair shift linkage
	Cavitation of propeller	Use lower engine speed or change propeller
	Broken propeller	Repair or replace propeller
	Broken shift shaft or fork inside transmission	Remove and repair transmission
No neutral	Damaged shift linkage	Repair shift linkage
	Forward or reverse clutch not releasing	Remove and repair transmission
Transmission overheats	Cooler water flow restricted or aerated.	Check engine water pump flow and tighten hose fittings
	Oil cooler required (but not installed)	Install oil cooler
Noisy in forward or reverse	Misalignment of flywheel housing or adapter with engine or transmission	Align power train components
	Misalignment of propeller shaft and transmission coupling flanges	Align coupling flanges.
	Worn or damaged gears	Remove and repair transmission
Noisy in neutral only	Worn or damaged gears	Remove and repair transmission

2-12. REMOVAL AND INSTALLATION

2-13. REMOVAL OF TRANSMISSION. Refer to the OEM manual for specific instructions regarding enclosures, supports, shift linkage, brackets and other components related to the transmission. A suitable hoist or other means for completely supporting the transmission will be required. Proceed as follows with the engine off (see figure 2-1):

1. Disconnect negative battery terminal.
2. Shift transmission into neutral.
3. Remove the dipstick (2).
4. Use a suction pump through the dipstick opening to remove fluid from the transmission or remove drain plug.
5. If transmission is equipped with oil cooler, provide suitable container to catch coolant water and disconnect water hoses from oil cooler (102).
6. Disconnect shift linkage and bracket (if used) from transmission shift lever (31).
7. Remove coupling nuts (107) and bolts (108), loosen setscrew (109), and completely separate propeller shaft and transmission coupling flange (110 and 5).
8. Support transmission with hoist or by other suitable means.



CAUTION: Make sure transmission is completely supported before removing bolts (104) attaching adapter plate (105) or, if used, bell housing. Do not allow transmission to "hang" on input shaft.

9. Remove six bolts (104) attaching adapter plate (105) or, if used, bell housing.
10. Move transmission straight back away from engine to completely disengage input shaft spline (28).
11. Carefully lift out transmission.
12. To remove adapter plate (105) or, if used, bell housing, take out six bolts (106).
13. To remove oil cooler, remove four bolts (101) and separate oil cooler (102) and gasket (103) from transmission.

2-14. REPAIR/OVERHAUL OF TRANSMISSION. Refer to Sections 3 through 5 for disassembly, inspection, repair, parts replacement and assembly of the transmission.

2-15. INSTALLATION OF TRANSMISSION. Refer to the OEM manual for specific instructions regarding enclosures, supports, shift linkage, brackets and other components related to the transmission. With transmission supported in a suitable manner, proceed as follows (see figure 2-1):

1. If transmission is equipped with oil cooler (102), attach with gasket (103), to transmission with four bolts (101). Torque bolts to 10-12 lb-ft (14-16 Nm).

2. Attach adapter plate (105) or, if used, bell housing to transmission with six bolts (106). Torque bolts to 10-12 lb-ft (13.6-16.3 Nm).

3. Apply a thin film of high temperature grease to spline on transmission input shaft (28).

4. Position transmission and align adapter plate (105) or, if used, bell housing with engine.



CAUTION: Make sure adapter plate or bell housing is in exact alignment with engine before engaging splines. Do not force transmission into place. Otherwise damage may result.

5. Carefully move transmission forward, engaging input shaft spline (28), until adapter or bell housing flange contacts engine. Make sure all holes are aligned and install six bolts (104). Torque bolts to 35-55 lb-ft (34-48 Nm). Remove hoist.

NOTE: If the boat is not in the water, defer the following coupling flange connection and alignment procedure until it is.

6. With the boat in the water, connect coupling flanges and check alignment as follows:

- a. Engage propeller shaft coupling flange (110) pilot with transmission coupling flange (5) and tighten setscrew (109).

- b. With the flange pilot engaged, check the clearance around the coupling flange using a 0.003 inch feeler gage.

- c. Rotate transmission flange through one complete revolution, stopping each 90 degrees to check the clearance with the feeler gage. Repeat this procedure with the propeller shaft flange.

- d. Alignment is satisfactory when the flanges are within 0.003 in. (0.076 mm) of parallel.

- e. If alignment is unsatisfactory, adjustment is required. This adjustment shall be done only at the motor mounts and then only by a qualified marine mechanic. Do not pry against the transmission output flange or propeller shaft flange to attempt alignment.

- f. When alignment is satisfactory, install four coupling flange bolts (108) and nuts (107). Torque to 25-43 lb-ft (34-58 Nm).

7. If used, install shift linkage bracket. With helm control in neutral, connect shift linkage with transmission shift lever (31) in neutral. Check transmission shift lever to ensure helm control provides for full travel from forward to reverse. Adjust linkage if necessary.

8. If transmission is equipped with oil cooler (102), connect water lines to cooler.

9. Fill transmission with fluid as specified in paragraphs 2-4 and 2-8.

10. Connect negative battery terminal.

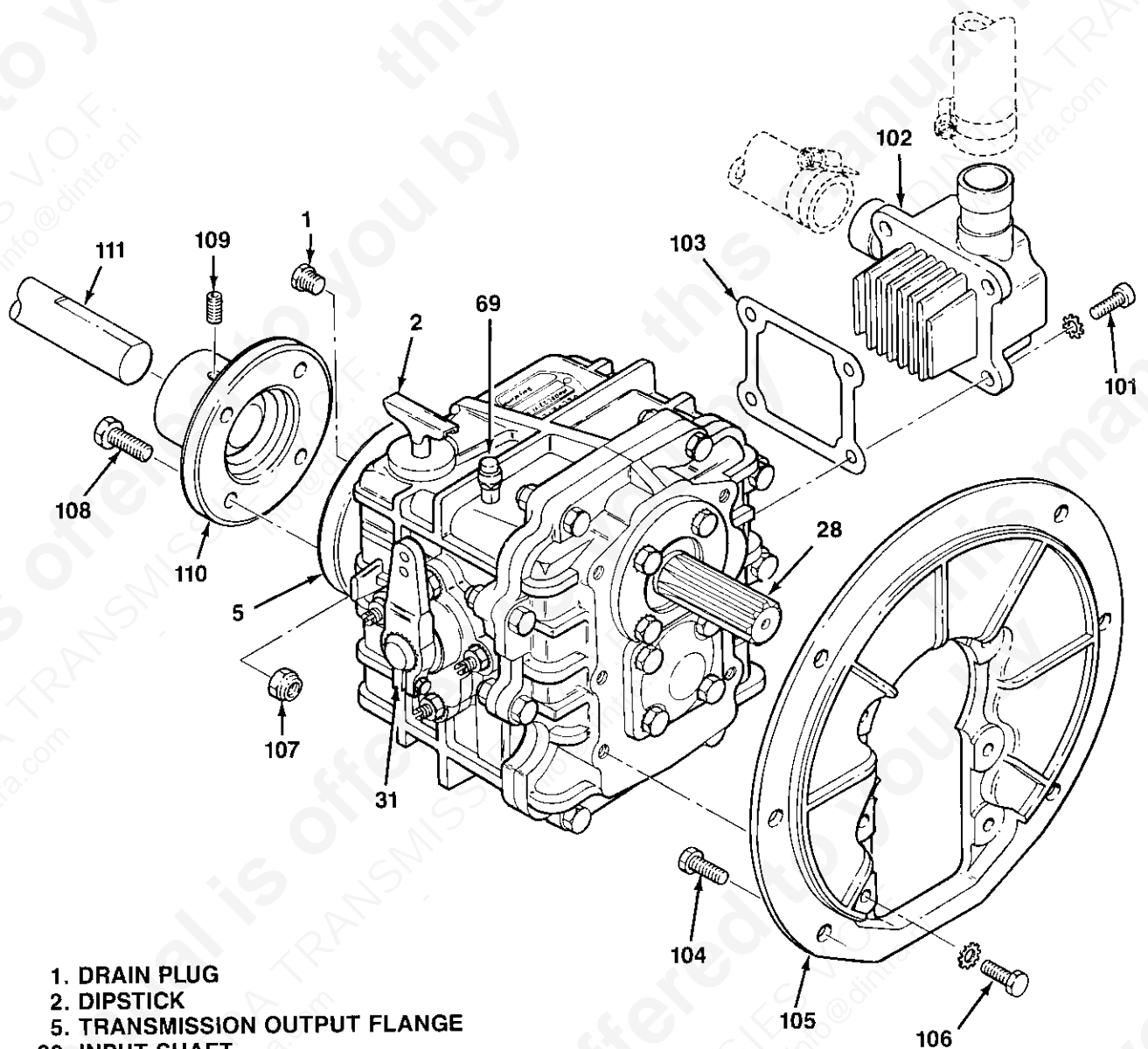

- 1. DRAIN PLUG
- 2. DIPSTICK
- 5. TRANSMISSION OUTPUT FLANGE
- 28. INPUT SHAFT
- 31. SHIFT LEVER
- 69. BREATHER
- 101. BOLT
- 102. OIL COOLER
- 103. GASKET
- 104. BOLT
- 105. ADAPTER PLATE
- 106. BOLT
- 107. NUT
- 108. BOLT
- 109. SETSCREW
- 110. PROPELLER SHAFT COUPLING FLANGE
- 111. PROPELLER SHAFT

0507

Figure 2-1. Transmission Installation

Section 3 Disassembly

3-1. GENERAL INFORMATION

3-2. During disassembly, refer to the illustrations provided with the text. In addition, an exploded view of the complete assembly can be seen on the illustration in Section P, Parts.

3-3. This section provides instructions for complete disassembly of the transmission as would be the case for overhaul. If the transmission is not due for overhaul, and repair affecting specific parts is required, disassemble only to the extent necessary to gain access to these parts. Parts removed from the transmission as subassemblies or groups need not be disassembled for repair unless they contain the affected parts. Total disassembly is recommended to ensure that all parts are absolutely clean.

3-4. REMOVAL AND INSTALLATION OF TRANSMISSION

3-5. Refer to paragraph 2-13.

3-6. TRANSMISSION DISASSEMBLY

3-7. REMOVAL OF EXTERNAL COMPONENTS. Shift the transmission into neutral, then begin disassembly as follows (see figure 3-1):

1. Remove drain plug (1) and dipstick (2) and drain any fluid from transmission. Discard drained fluid.

2. Holding output flange (5) with coupling wrench T-504, remove nut (3) and washer (4). Remove output flange (5) and o-ring (6).

3. If transmission is not installed with an oil cooler, do not remove cooler opening cover (8) unless replacement is required. Then, remove four bolts (7) and cooler opening cover (8). Remove gasket (9).

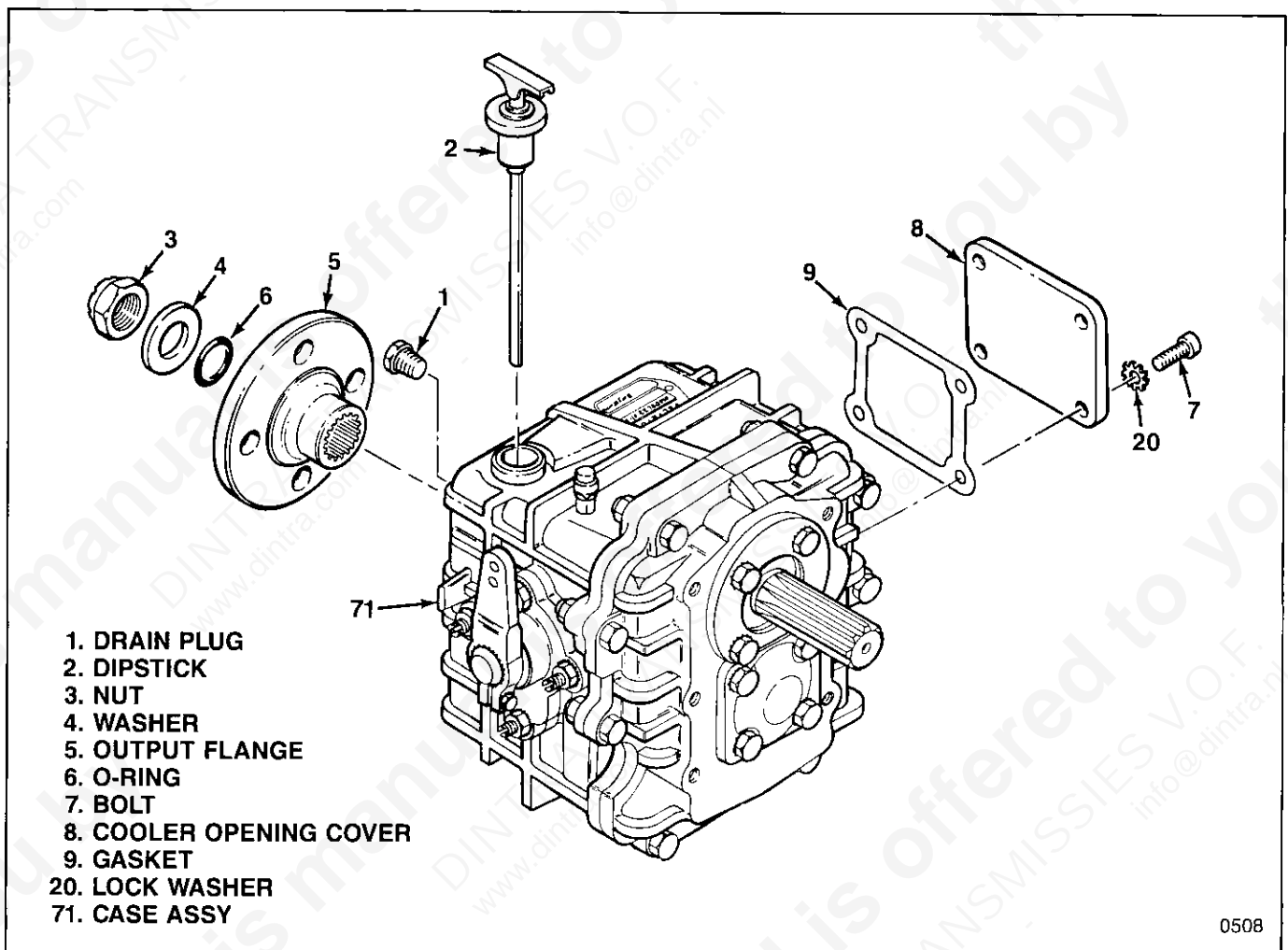

Figure 3-1. External Components

0508

3-8. REMOVAL OF BEARING CAPS AND ADAPTER ASSEMBLY. Position the transmission with the input shaft end up. Support the transmission on wooden blocks to provide clearance for the output shaft. Proceed as follows (see figure 3-2):

1. Remove eight bolts (10), washers (11), caps (12 and 13) and gaskets (14).
2. Press oil seal (15) from circular cap (12) using suitable drift.

3. Remove shims (16) installed under each cap (12 and 13) and keep separate.

4. Remove eight nuts (17), two bolts (18), six bolts (19) and eight lock washers (20).

5. Remove adapter (21) and gasket (23). Pull needle bearing (22) from adapter only if replacement is required.

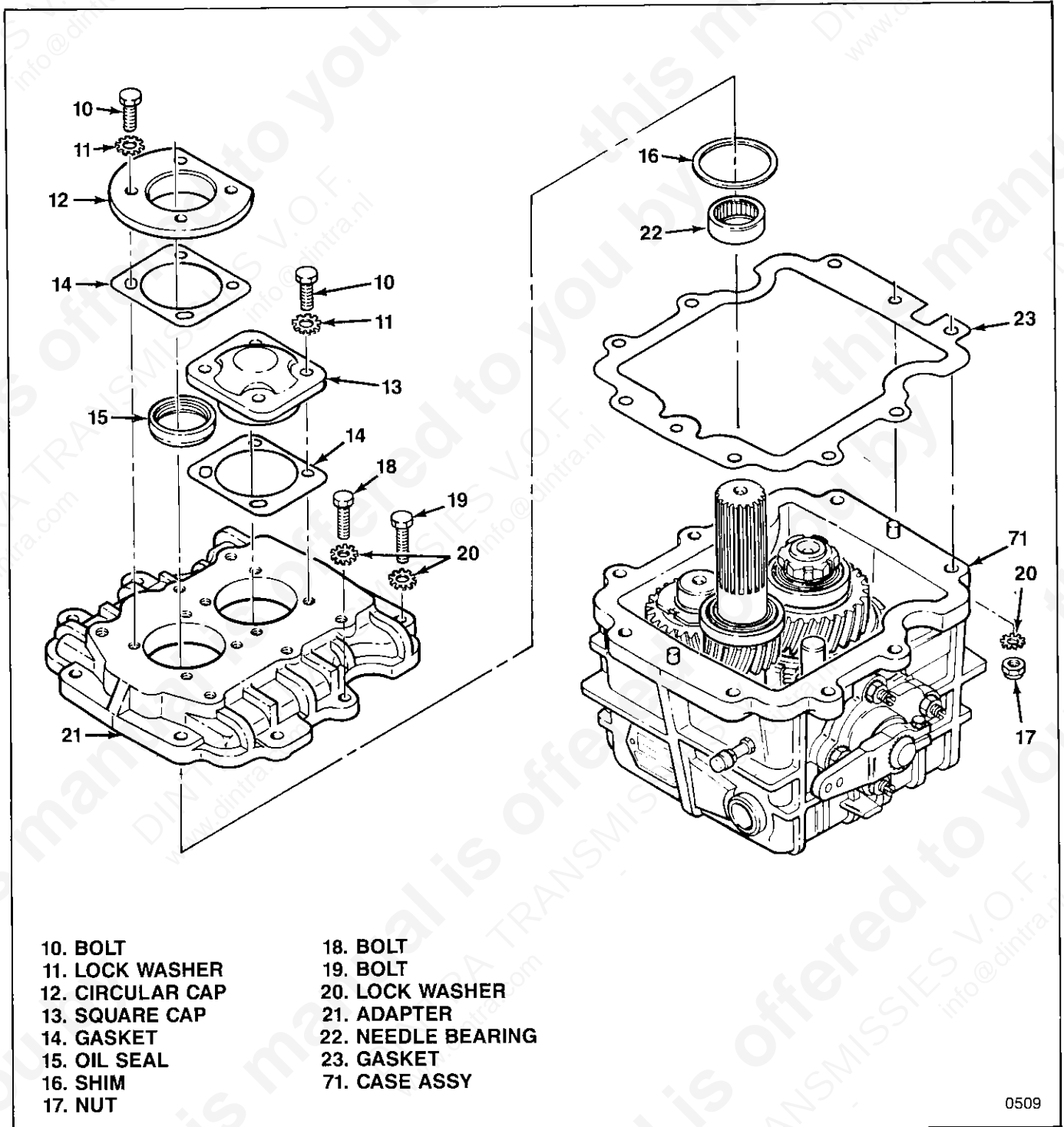



Figure 3-2. Bearing Caps and Adapter Assembly

3-9. REMOVAL OF IDLER AND INPUT SHAFT GEARS. With input end of transmission up, proceed as follows (see figure 3-3):

1. Remove thrust washer (24) and idler gear (25) from transmission.
2. Remove bearing cup (26) and input shaft gear (28) with two bearing cones (27) attached.
3. Pull bearing cones (27) from input shaft gear (28) only if replacement is required.

 **CAUTION:** Bearing cones pulled from input shaft gear must be replaced.

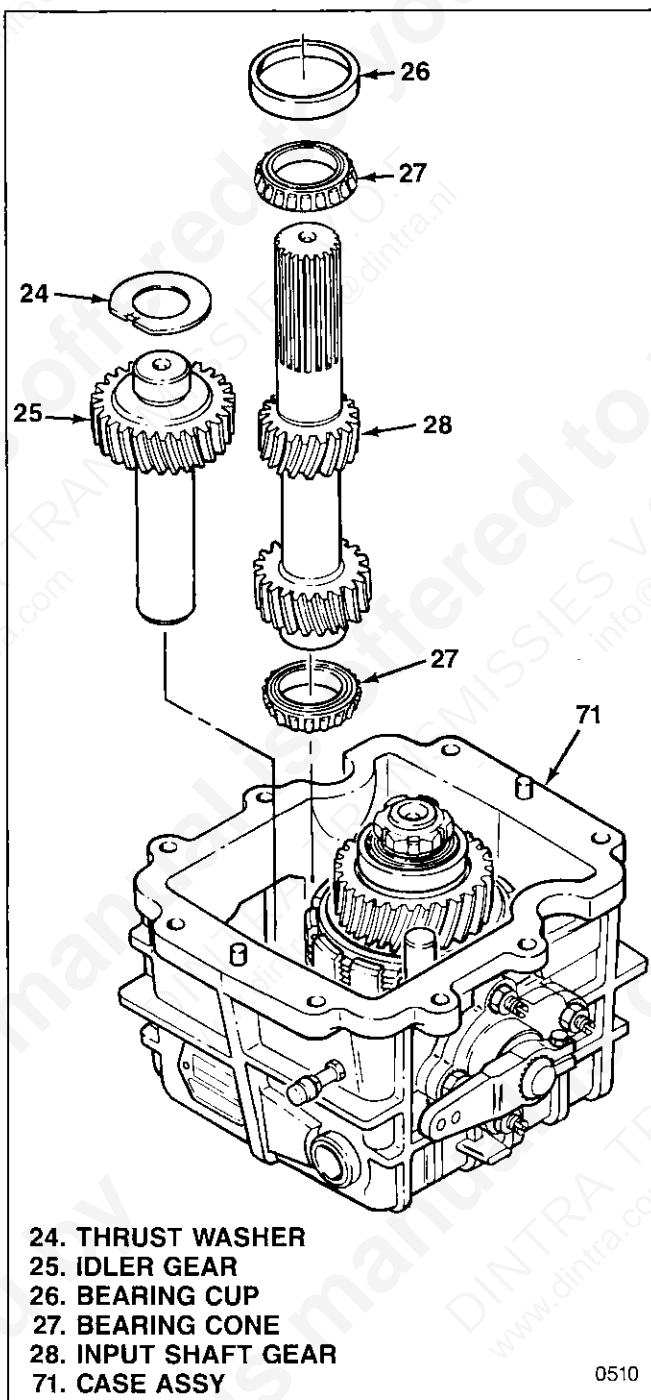

Figure 3-3. Idler and Input Shaft Gears

3-10. REMOVAL OF SHIFTING MECHANISM AND OUTPUT SHAFT GROUP. Proceed as follows (see figure 3-4):

1. Remove bolt (29), lock washer (30) and shift lever (31).
2. Remove four nuts (32) and withdraw shift housing and shaft group (34 through 39) from transmission.

NOTE

Thrust block (42) may become dislodged as shifting shaft (35) is withdrawn from transmission. If so, retrieve thrust block now or after output shaft group is removed from transmission.

3. Remove shifting shaft (35), steel ball (36) and spring (37) from shift housing (34).
4. Press oil seal (38) and two needle bearings (39) from shift housing (34).
5. Remove gasket (40). Remove four studs (41) from transmission case only if replacement is required.
6. Grasp shift fork (43) and output shaft group (90) and withdraw from transmission together. Remove thrust block (42) and separate shift fork from output shaft group.
7. Remove shift rail (44) from transmission.

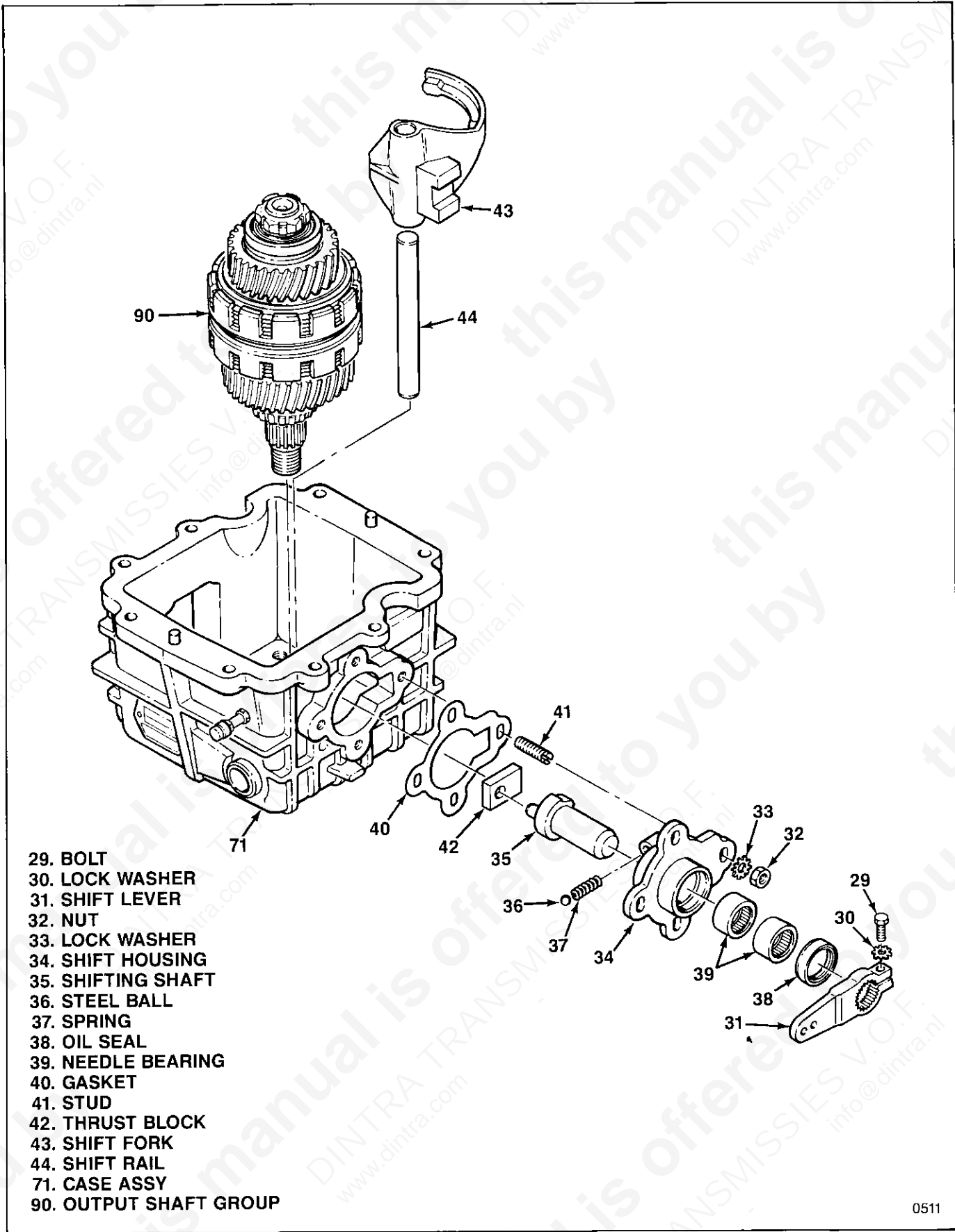

Figure 3-4. Shifting Mechanism and Output Shaft Group

3-11. DISASSEMBLY OF OUTPUT SHAFT GROUP. Proceed as follows (see figure 3-5):

1. Temporarily re-install output flange (5, figure 3-1) on output shaft (67) to hold shaft with coupling wrench T-504. Loosen lock nut (45) using socket wrench and socket T-505.

2. Remove lock nut (45), lock washer (46), bearing spacer (47) and bearing cup (48).

3. From each end of output shaft (67), remove the following:

a. One bearing cone (49). Use suitable puller behind reverse gear (52) and output gear (53) to unseat bearing cones from output shaft (67).

b. One thrust washer (50) and shims (51).

c. Reverse gear (52) and output gear (53) with attached parts (54 through 59). From each gear remove the following:

(1) One snap ring (54).

(2) Alternately, five clutch plates (55) and four clutch plates (56).

(3) One snap ring (57). Use compression tool T-501 on clutch backup plate (58) in arbor press to compress disc spring (59) when removing snap ring (57) from reverse gear (52) or output gear (53) (see figure 3-6).

(4) One clutch backup plate (58).

(5) One disc spring (59).

d. Continuing with output shaft group, from each end remove one spring (60).

e. One needle bearing (61). Pull inner bearing rings (62) using suitable puller behind thrust washers (63).

f. One thrust washer (63) and spacer (64).

4. Slide shift collar (65) off output shaft (67) freeing 64 steel balls (66).

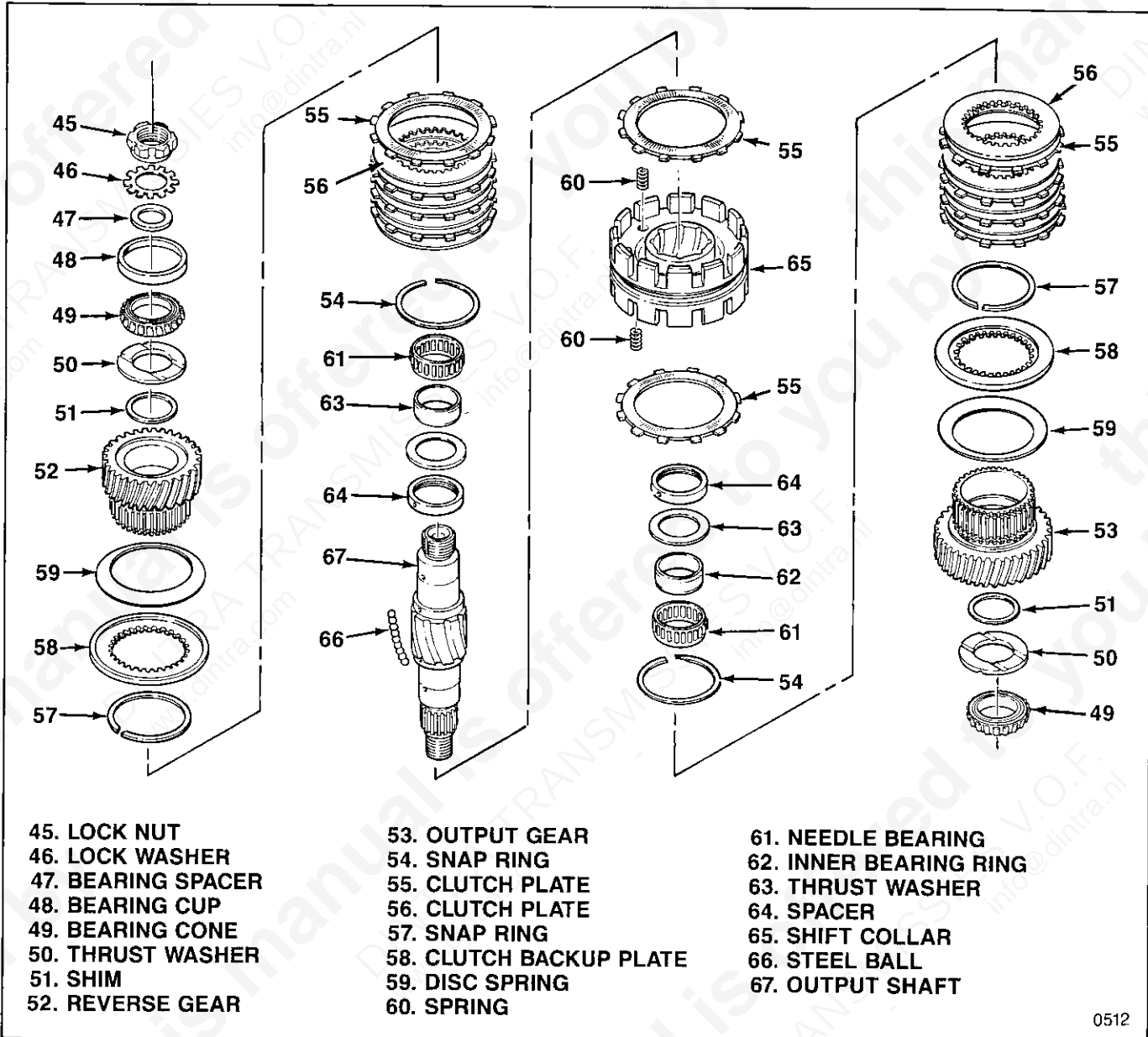

Figure 3-5. Output Shaft Group

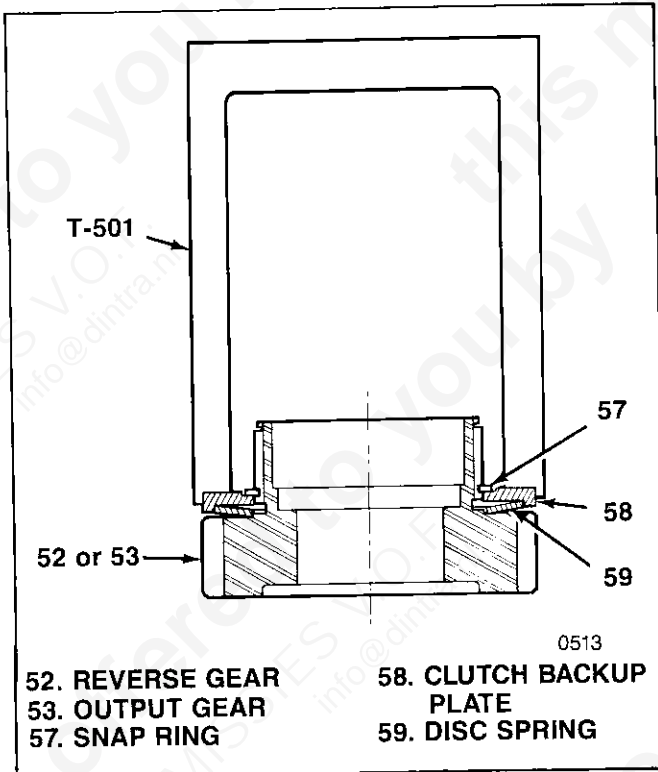

Figure 3-6. Removing Gear Snap Ring

3-12. DISASSEMBLY OF TRANSMISSION CASE.
Remove the following parts from the transmission case (see figure 3-7):

1. Press out oil seal (68) using suitable drift.
2. Remove breather (69).
3. Remove dowel pins (72) from case and magnet assembly (76) only if replacement is required.
4. Pull needle bearing (73) from case and magnet assembly (76) only if replacement is required. Then, remove thrust washer (74).
5. Pull bearing cups (75) from case and magnet assembly (76) only if replacement is required.

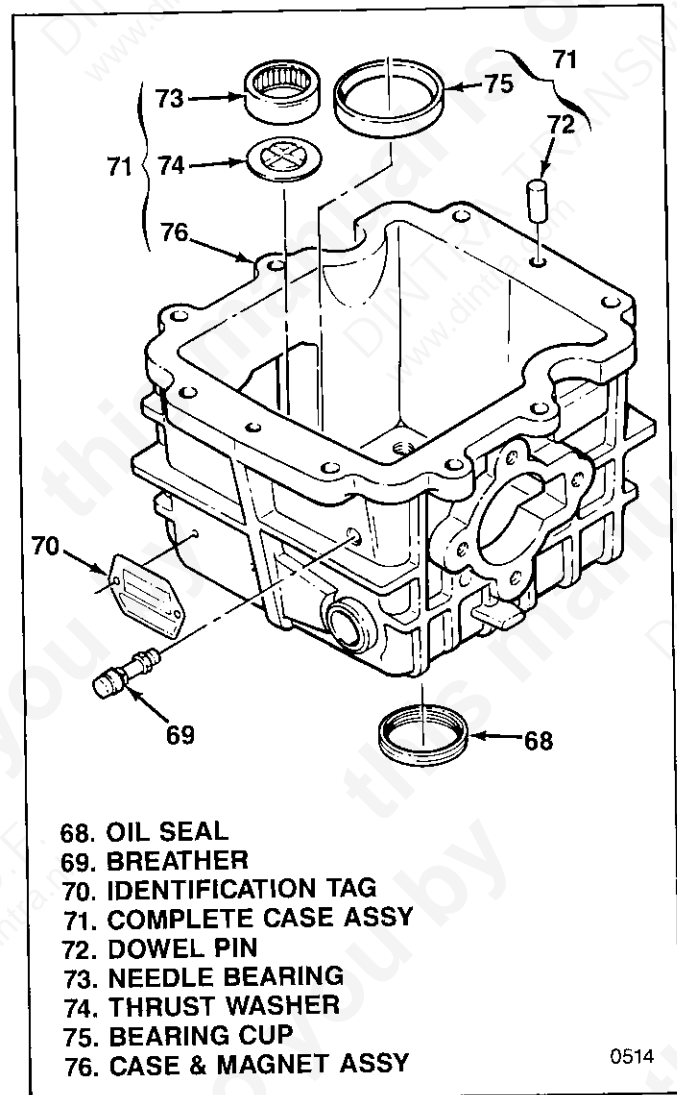

Figure 3-7. Transmission Case

Section 4

Cleaning, Inspection, Repair or Replacement

4-1. CLEANING

NOTE: Prior to cleaning transmission case, check magnet cemented in case bottom for presence of metal particles. Larger, granular or irregular shaped particles indicate chipping or similar damage. Smaller, powder-like particles indicate uneven or excessive wear. If metal particles are detected, be on the lookout for damage or wear when inspecting rotating parts and those with which they mate.

4-2. GENERAL CLEANING PROCEDURE. Wash parts in cleaning solvent to remove old lubricant and dirt deposits. Use a bristle brush to remove caked-on deposits. Parts that cannot be cleaned by brushing may be scraped but use care not to damage metal surfaces.

4-3. DRYING CLEANED PARTS. Dry parts with low pressure (20 psi max) compressed air. Wiping parts dry could leave lint deposits.

4-4. LUBRICATING BEARINGS. Immediately after cleaning, lubricate needle bearings (22, 39, 61 and 73, figure P-1) and roller bearing cones (27 and 49) with transmission lubricant (refer to paragraph 2- 4). Rotating or spinning dry, unlubricated bearings could result in damage. Cover lubricated bearings to protect from dust.

4-5. INSPECTION

4-6. GENERAL INSPECTION PROCEDURES. Visually inspect all parts except o-rings, oil seals and gaskets, which should be replaced with new parts. Inspect for damage or excessive or uneven wear. Replace parts with damage or wear that would affect serviceability of the part. Inspection terms used in this section are as follows:

- Burr:** Local rise of material forming protruding sharp edge.
- Chip:** An area from which a small fragment has been broken off or cut.
- Crack:** Surface break of line nature indicating partial or complete separation of material.
- Excessive wear:** Heavy or obvious wear beyond expectations considering conditions of operation.
- Indentation:** Displacement of material caused by localized heavy contact.
- Galling:** Breakdown (or build-up) of metal surface due to excessive friction between parts. Particles of the softer material are torn loose and welded to the harder material.
- Nick:** Local break or notch. Usually displacement of material rather than loss.

Scoring: Tear or break in metal surface from contact under pressure. May show discoloration from heat produced by friction.

Step wear: Heavy wear that produces a step that can be seen or felt between adjacent contact and non-contact surfaces.

Uneven wear: Condition of localized, unevenly distributed wear. Includes hollows, shiny spots, uneven polish and other visual indications.

4-7. SPECIFIC INSPECTION PROCEDURES. Inspect parts in accordance with Table 4-1 and as specified in the following paragraphs. Index numbers used in Table 4-1 are those assigned to the exploded view in Section P, Parts.

4-8. GEAR TEETH INSPECTION. When specified in Table 4-1, inspect gear teeth as follows:

NOTE: Do not confuse gear contact wear patterns with normal tool marks that are a result of manufacture. Typical tool marks are shown in figure 4-1.

a. Check gear tooth contact wear patterns. Gears showing evidence of excessive or irregular wear shall be replaced.

b. Check gear teeth for chips. Gears with chipped or broken teeth part must be replaced.

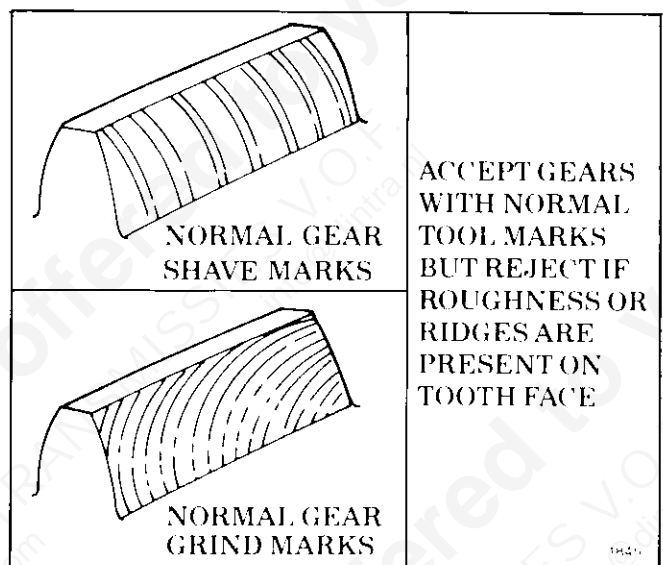

Figure 4-1. Normal Gear Tooth Tool Marks

4-9. SPLINE TEETH INSPECTION. Check for broken or chipped spline teeth. If any spline tooth is chipped or broken, the part must be replaced. Spline teeth will not show contact patterns as gear teeth do. However, they may show evidence of step wear which is cause for replacement.

Table 4-1. Inspection

PART (INDEX NO.)	INSPECTION	ACCEPT/REJECT
All parts (including all springs)	Check for cracks	Replace parts with cracks
	Check for distortion	Replace parts that are bent, distorted or out of round
All threaded parts	Check for stripped, crossed or otherwise damaged threads	Replace parts with threads that cannot be cleaned up using a suitable tap or die
Cooler opening cover (8), caps (13 and 13), adapter (21) and case (76)	Check mating faces for burrs or other damage that would prevent proper seating of mating faces and cause leaks	Remove small burrs per paragraph 4-12. Otherwise, replace damaged parts
Output flange (8)	Check spline per paragraph 4-9	Paragraph 4-9
Adapter (21)	Check bearing bores	Replace if scored
Needle bearings (22, 39, 61 and 73)	Check rollers and races for chipping, galling scoring or other damage	Replace damaged bearings
Thrust washers (24, 50 and 63)	Check for distortion, scoring or wear	Replace if bent, scored or if step wear is noted
Idler gear	Check bearing journals for scoring	Replace if scored or damaged
	Check gear teeth per paragraph 4-8	Paragraph 4-8
	Check for distortion	Replace if bent or out of round
Roller bearing cups (26, 48 and 75) and cones (27 and 49)	Check cups, rollers and races for chipping, galling, scoring or other damage	Replace damaged bearing cups or cones
	Make sure bearing cone is lubricated, Slowly rotate rollers, feeling for binding, roughness or flat spots. Rollers must rotate smoothly without side or end play	Replace bearing cones with damaged or loose rollers
Input shaft gear (28)	Check gear teeth per paragraph 4-8	Paragraph 4-8
	Check ID for needle bearing	Replace if scored or damaged
Shift lever (31)	Check for distortion	Replace if bent
Shift housing (34)	Check ID for needle bearing	Replace of scored or damaged
Shifting shaft (35)	Check bearing journals	Replace if scored or damaged
	Check eccentric for scoring or wear	Replace if scored or if step wear is noted
Steel balls (36 and 66)	Check for nicks, burrs or flat spots	Replace worn or damaged balls
Thrust block (42)	Check for scoring or wear	Replace if scored, damaged or if step wear is noted

Table 4-1. Inspection (cont.)

PART (INDEX NO.)	INSPECTION	ACCEPT/REJECT
Shift fork (43)	Check ends that engage shift collar (65) for wear or damage	Replace if damaged or if step wear is noted
	Check bore that mates with shift rail and slot for thrust block for scoring	Replace if scored or damaged
Shift rail (44)	Check for distortion	Replace if bent
	Check for OD for burrs or other damage	Remove small burrs per paragraph 4-12. Otherwise, replace if damaged
Reverse and output gears (52 and 53)	Check gear teeth per paragraph 4-8	Paragraph 4-8
	Check ID for needle bearing	Replace if scored or damaged
	Check external spline per paragraph 4-9	Paragraph 4-9
Clutch plates (55) and mating faces of clutch plates (56), backup plates (58) and shift collar (65)	Check for scoring or warping	Replace if scored or damaged. Mating faces must be smooth. Clutch plates must be flat
Clutch plates (55)	Broken or cracked drive tangs on OD	Replace plates with damaged drive tangs
Clutch plates (56) and backup plates (58)	Check internal splines per paragraph 4-9	Paragraph 4-9
Inner bearing rings (62)	Check for scoring	Replace if scored or damaged
Shift collar (65) and output shaft (67)	Check mating ball grooves for damage	Replace if scored or damaged
Output shaft (67)	Check spline per paragraph 4-9	Paragraph 4-9
	Check bearing journals	Replace if scored or damaged
	Check for distortion	Replace if bent or out of round
Case (76)	Check bearing bores	Replace if scored or damaged

4-10. PARTS REPLACEMENT

4-11. Parts which fail to pass inspection shall be replaced unless repair procedures specified in the following paragraph, or other obvious minor repair, will restore the part to complete serviceability. If there is any doubt about the serviceability of a part, replace it.

4-12. **REMOVING SMALL BURRS.** Use a suitable abrasive stone to remove burrs. Be careful to remove only raised material, not base metal.

4-13. **SERVICE KIT.** Service kit part number 2301-410-001 is recommended when servicing the transmission. This kit contains oil seals, o-rings, gaskets and other small parts that normally require replacement.

Table 4-2. Service Kit Part Number 2301-410-001

QTY	PART NUMBER	DESCRIPTION
1	1000-044-062	Seal, Oil, output shaft
1	1000-044-063	Seal, Oil, shifting shaft
1	1000-044-064	Seal, Oil, input shaft
1	1000-141-476	O-ring, output shaft
1	1000-149-010	Nut, Lock, output shaft
2	2301-045-001	Gasket, cover plate
1	2301-045-002	Gasket, shift housing
1	2301-045-003	Gasket, case to adapter
1	2301-045-004	Gasket, cooler cover

Section 5 Assembly

5-1. GENERAL INFORMATION

5-2. During assembly, refer to the illustrations specified in the text. In addition, an exploded view of the complete assembly can be viewed in Section P, Parts. Note the following during assembly:

1. When a torque value is specified, use a torque wrench to tighten the threaded part. Torque values are specified in the text and also in Table 5-1 at the end of this section.

2. Coat small parts with petrolatum to help hold them in place during assembly.

5-3. **LUBRICATION DURING ASSEMBLY.** Lubricate all internal parts, not coated with petrolatum, with approved transmission lubricant (refer to paragraph 2-4) just prior to assembly. This will ease assembly and provide initial lubrication.

1. O-rings and shaft seal lips may be damaged during assembly if not lubricated.

2. Make sure bearing cones (27 and 49, figure P-1) and needle bearings (22, 61 and 73) are thoroughly lubricated before assembly. Running bearings dry, even for a brief period, will cause damage.

5-4. TRANSMISSION ASSEMBLY

5-5. **TRANSMISSION CASE.** If removed, assemble parts in transmission case as follows (see figure 5-1):

1. If removed, press in new bearing cups (75) to bottom in case and magnet assembly (76) using suitable drift.

2. If removed assemble thrust washer (74) and press new needle bearing (73) in to bottom in case and magnet assembly (76) using suitable drift.

3. If removed, press in new dowel pins (72) to project 0.49-0.51 in. (12.4-13.0 mm) above face of case and magnet assembly (76).

4. If removed, transfer all data from old identification plate (70) to new plate and attach to case assembly (71) using Silastic RTV No. 732 or GE Simate RTV No. 1473.

5. Install breather (69).

6. Using suitable drift, press new oil seal (68) into bore for output shaft. Position shaft seal as shown in figure 5-2.

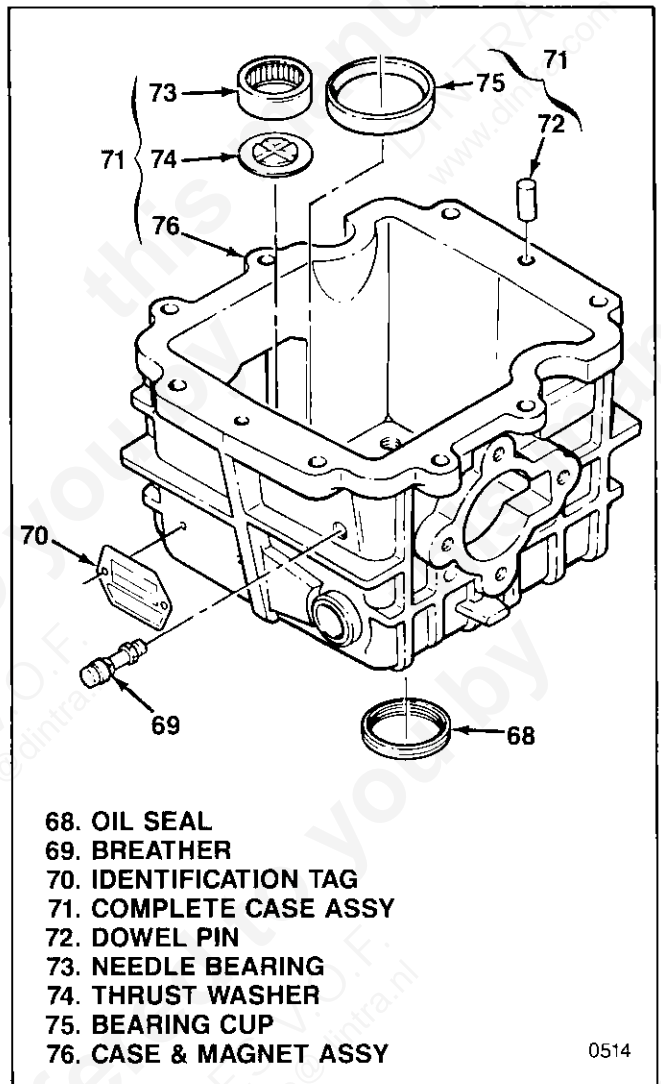

Figure 5-1. Transmission Case

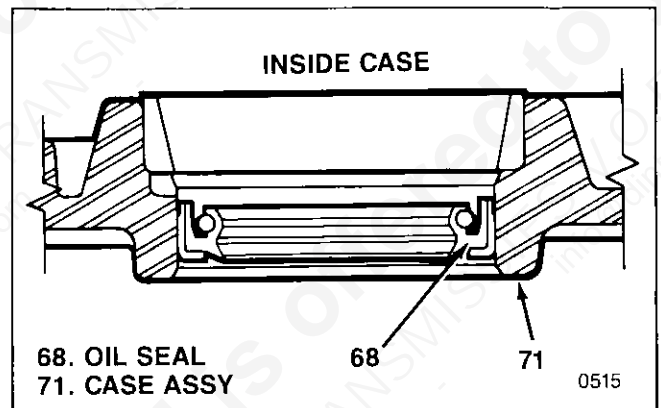

Figure 5-2. Shaft Seal Installation

5-6. ASSEMBLY OF GEAR AND CLUTCH PLATE GROUPS. Clutch plates and related parts (54 through 59) are assembled to output gear (53) or reverse gear (52) in the same manner. Proceed as follows for each gear and clutch plate group (see figure 5-3):

1. Place gear (53 or 52) on work surface, splined end up, and position disc spring (59) on gear, concave side up.

2. Position clutch backup plate (58) on disc spring (59).

3. Use compression tool T-501 on clutch backup plate (58) in arbor press to compress disc spring (59) (see figure 5-4). Fit expander T-502 over end of gear hub (see figure 5-4) and install snap ring (57) in groove in gear (53 or 52) next to clutch backup plate.

4. Starting with clutch plate (55) alternately place five clutch plates (55) and four clutch plates (56) on each gear (53 or 52).

5. Install snap ring (54) in groove in gear (53 or 52) furthest from gear end. Outer clutch plate (55) will be loose—not retained by snap ring—on each clutch plate group.

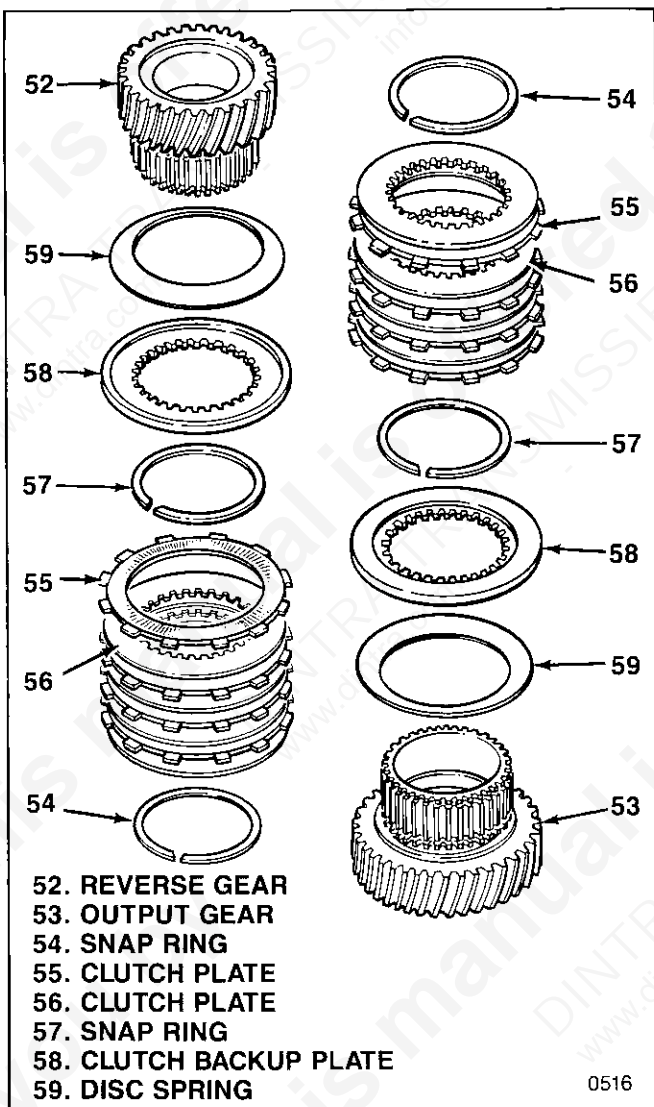

Figure 5-3. Gear and Clutch Plate Groups

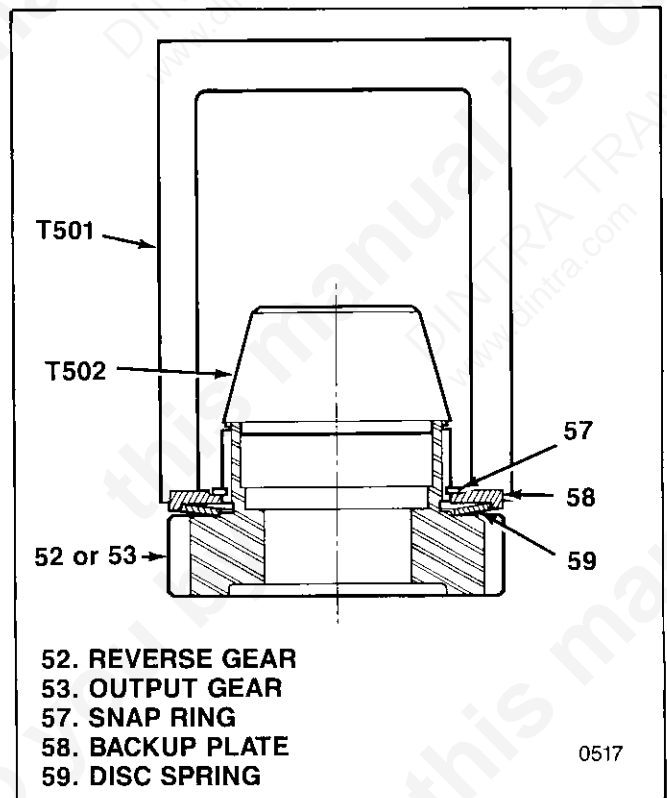

Figure 5-4. Installing Gear Snap Ring

5-7. SHIMMING OUTPUT SHAFT GROUP. Determine the thickness of shims (51) required for proper shifting as follows (see figure 5-5):

1. Support output shaft (67) with splined end up, threaded end down. Install parts as follows over splined end of output shaft only:

- a. One spacer (64).
- b. One thrust washer (63).
- c. One inner bearing ring (62). Use thrust washer (50) and bearing drift T-503 to press inner bearing ring onto output shaft (67) until ring bottoms out.
- d. One needle bearing (61).
- e. Output gear and clutch group (53 through 59) previously assembled.
- f. Shims (51) with thickness totalling 0.073 in. (1.84 mm).

- g. One thrust washer (50).
- h. One bearing cone (49). Use bearing drift T-503 to press bearing cone onto output shaft (67) until bearing cone bottoms out.

2. Invert output shaft (67) and assembled parts and support in suitable fixture with threaded end up, splined end down. An output flange (5, figure P-1) bolted to a metal block with a central hole for shaft clearance (see figure 5-6) makes a suitable fixture. Temporarily install parts as follows over threaded end of output shaft only:

- a. Shift collar (65). Do not install steel balls (66) or springs (60) at this time.
- b. One spacer (64).
- c. One thrust washer (63).

- d. One inner bearing ring (62). Use thrust washer (50) and bearing drift T-503 to press inner bearing ring onto output shaft (67) until ring bottoms out.
- e. One needle bearing (61).
- f. Reverse gear and clutch group (52 and 54 through 59) previously assembled.
- g. One thrust washer (50). Do not install shims (51) at this end of shaft at this time.

3. Position output shaft as assembled on holding fixture in arbor press (see figure 5-6). Install bearing drift T-503 over threaded end of shaft and clamp on thrust washer (50) with press ram. Make sure parts are bottomed out but do not use excessive force.

4. Position dial indicator on bottom side of groove in shift collar (65) as shown in figure 5-6).

5. By hand, press down firmly on shift collar (65) to make sure clutch pack is bottomed out, and zero dial indicator. Next, lift up firmly on shift collar and read dial indicator. Record dial indicator reading as dimension "D".

6. Calculate "T", the thickness of shims required at threaded end of output shaft, as follows:

$$T = 0.140 - D \text{ in inches, or}$$

$$T = 3.56 - D \text{ in mm}$$

7. Record "T", the thickness of shims required.

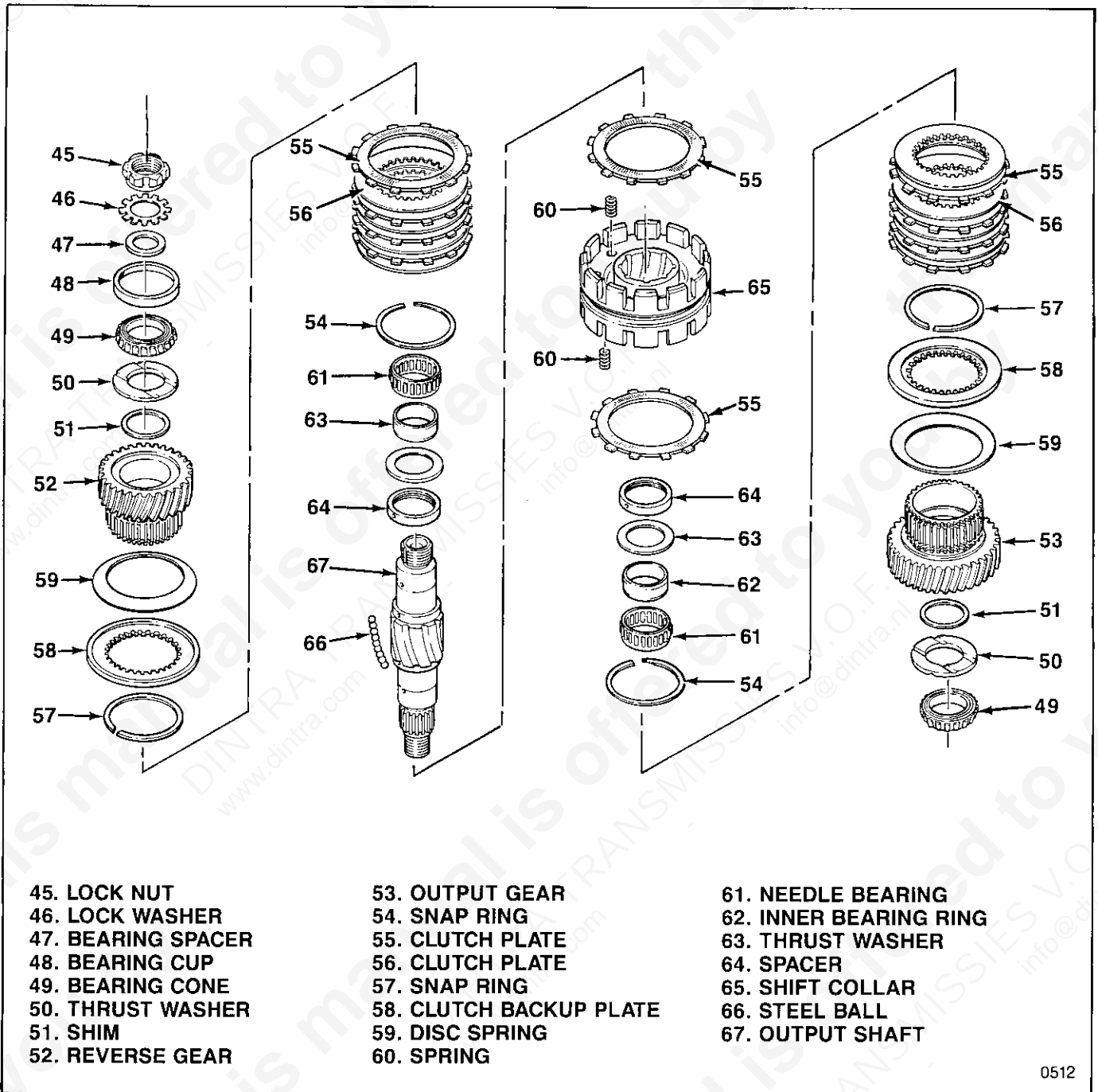

Figure 5-5. Output Shaft Group

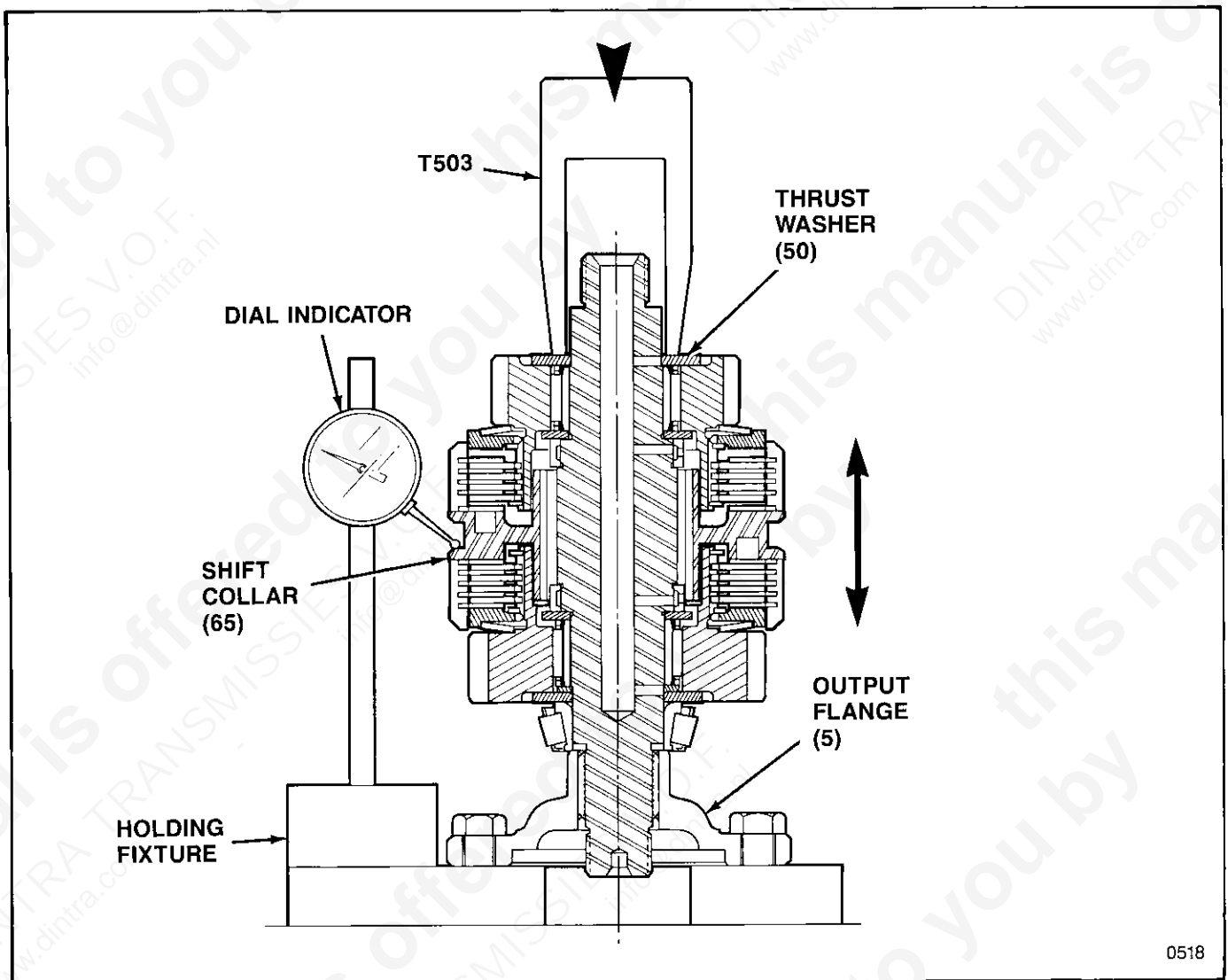

Figure 5-6. Measuring For Output Shaft Shim

5-8. FINAL ASSEMBLY OF OUTPUT SHAFT GROUP. Remove output shaft group as assembled on holding fixture for shim measurements from arbor press and remove bearing drift from shaft. Proceed as follows (see figure 5-5):

1. Remove parts temporarily installed on threaded end of output shaft (67) in paragraph 5-7.2 steps a through g. Also remove the one, loose clutch plate (55) from each gear and clutch plate group.

2. Stand shift collar (65) on edge and install one spring (60) in holes in each side of shift collar (two springs total). Install loose clutch plates (55), one in each side of shift collar to hold springs in place.

3. Tilt output shaft, as assembled on holding fixture, over so that shaft is approximately horizontal. Align shift collar (65) with notches in clutch pack (55 and 56) in output gear (53) and install shift collar with springs (60) and clutch plates (55) so that loose clutch plate is in firm contact clutch pack in output gear. Then stand assembled output shaft and fixture upright.

4. Rotate shift collar (65) to align notches in collar and output shaft (67) and install 64 steel balls (eight balls in each of eight openings).

5. Re-install parts on threaded end of output shaft (67) as described in paragraph 5-7.2, steps b through f only.

6. Install thickness of shims (51) "T" recorded in paragraph 5- 7.7.

7. Install one thrust washer (50).

8. Install one bearing cone (49). Use bearing drift T-503 to press bearing cone onto output shaft (67) until bearing cone bottoms out against thrust washer (50).

9. Install bearing spacer (47), lock washer (46) and lock nut (45). Holding output flange (5) with coupling wrench T-504, torque lock nut to 42-50 lb-ft (60-68 Nm) using socket wrench and socket T-505.

10. Using 0.140 in. (3.56 mm) feeler gage, check total clearance in clutch stack-up. If necessary, remove parts and adjust thickness of shim(s) (51) installed in step 6. Increasing shim thickness will increase clutch stack-up clearance and vice versa.

11. When clutch clearance is satisfactory, bend tabs on lock washer (46) to secure.

12. Position bearing cup (48) over bearing cone (49) and remove assembled output shaft group from holding fixture.

5-9. INSTALLING SHIFTING MECHANISM AND OUTPUT SHAFT GROUP. After shimming and assembly of output shaft group is completed, proceed as follows to install it and shifting mechanism in transmission (see figure 5-7):

1. If removed, install four studs (41) in transmission case. Installed studs shall project 0.81-0.82 in. (20.6-20.8 mm) above face of case.

2. Assemble shift housing and shaft group (34 through 39):

a. Using suitable drift, press two needle bearings (39) and one shaft seal into shift housing (34). Installed parts shall be positioned as shown in figure 5-8).

b. Install spring (37) and steel ball (36) in shift housing (34). Using small screwdriver to press in on ball and compress spring, install shifting shaft (35) in shift housing so that center (neutral) notch in shifting shaft engages ball.

3. Install gasket (40) over studs (41) on transmission case.

4. Position case assembly (71) with open (input shaft) end up. Support case on wooden blocks to provide clearance for output shaft when installed. Install shift rail (44) in blind hole in transmission case.

5. Engage shift fork (43) with shift collar on output shaft group (90) and install assembly in transmission case, sliding shift fork down over shift rail (44). Make sure bearing cone on end of output shaft group goes into bearing cup in case.

6. Position thrust block (42), end closest to hole toward top of transmission case, in slot in shift fork (43) and hold in place. Install shift housing and shaft group (34 through 39), engaging eccentric on shifting shaft (35) in hole in thrust block.

7. Attach shift housing with four lock washers (33) and four nuts (32). Torque nuts to 7-9 lb-ft (9-12 Nm).

8. Install shift lever (31) on shifting shaft (35) with lever pointing straight up, towards top of case (see figure 1-1). Install lock washer (30) and bolt (29) and torque to 3.5-4.5 lb-ft (4.7-6.1 Nm).

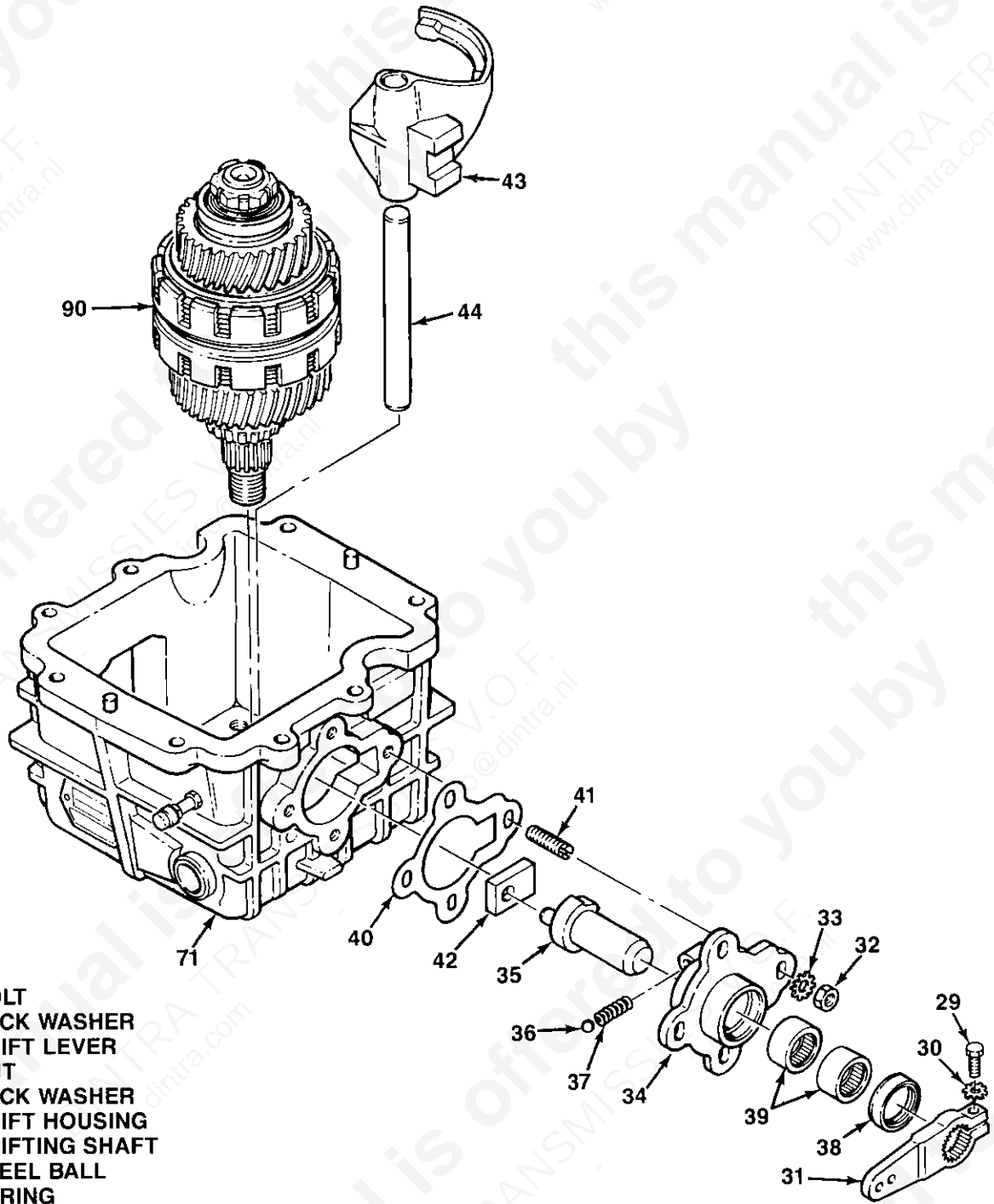

- 29. BOLT
- 30. LOCK WASHER
- 31. SHIFT LEVER
- 32. NUT
- 33. LOCK WASHER
- 34. SHIFT HOUSING
- 35. SHIFTING SHAFT
- 36. STEEL BALL
- 37. SPRING
- 38. OIL SEAL
- 39. NEEDLE BEARING
- 40. GASKET
- 41. STUD
- 42. THRUST BLOCK
- 43. SHIFT FORK
- 44. SHIFT RAIL
- 71. CASE ASSY
- 90. OUTPUT SHAFT GROUP

Figure 5-7. Shifting Mechanism and Output Shaft Group

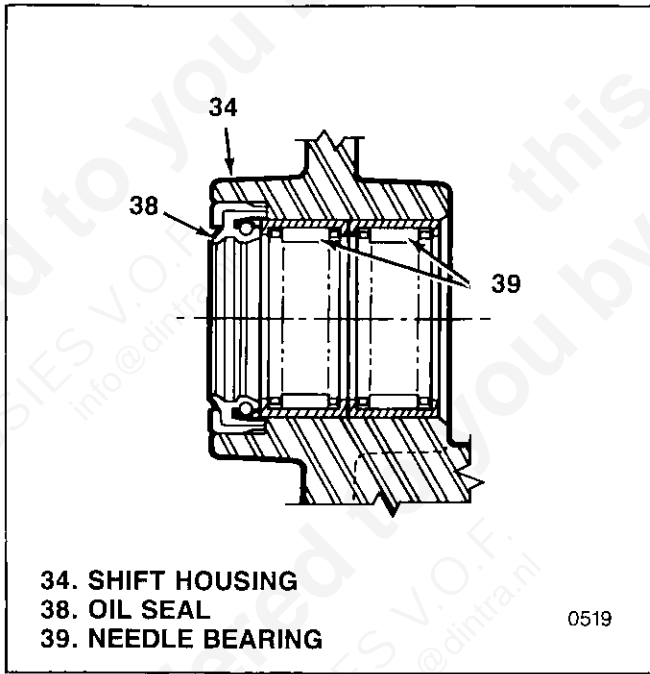

Figure 5-8. Oil Seal Installation

5-10. INSTALLING INPUT AND IDLER SHAFT GEARS. Install as follows (see figure 5-9):

1. If removed, install two new bearing cones (27) on input shaft gear (28). Use bearing drift T-503 to press each bearing cone onto input shaft until bearing cone bottoms out against gear face. Position bearing cup (26) on bearing cone closest to splined end of shaft.

2. Install input shaft gear (28), with bearing cones (27), in case assembly (71), splined end up. Engage bearing cone on bottom end of input shaft gear with bearing cup in case.

3. Install idler gear (25) in needle bearing in case assembly (71) with gear end up. Install thrust washer (24) on upper end of idler gear, against gear face.

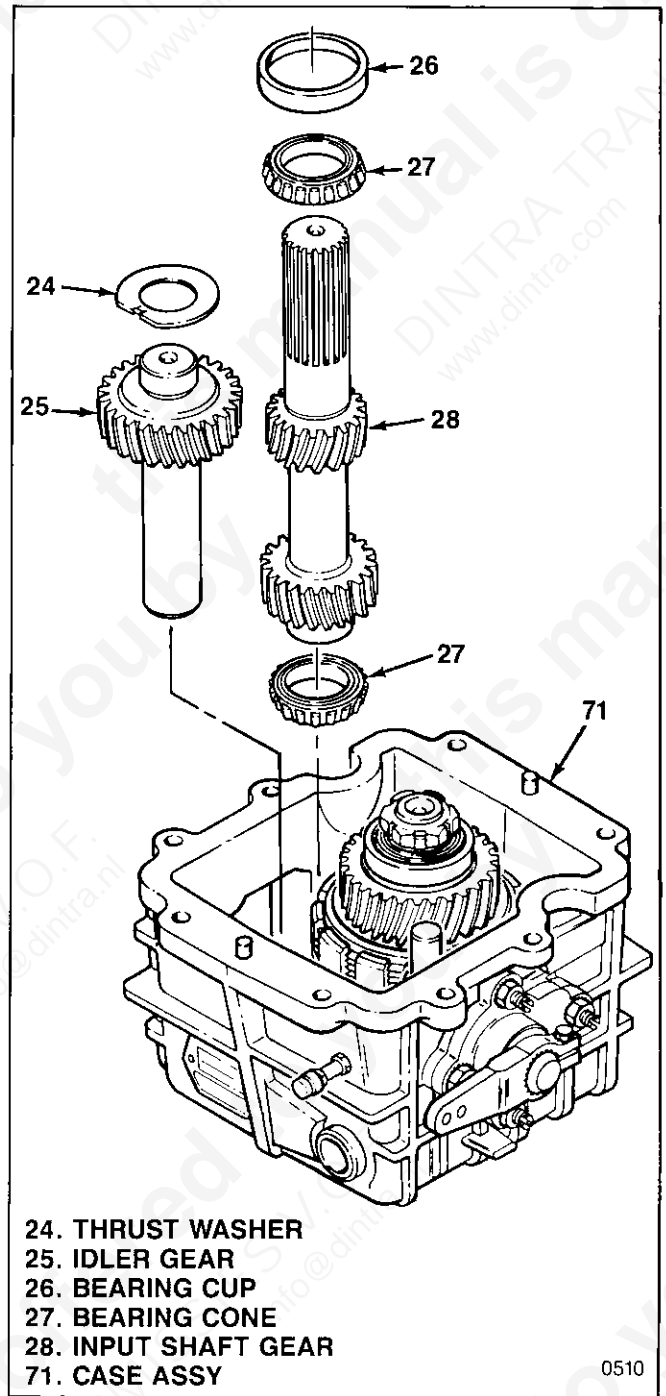

Figure 5-9. Input Shaft and Idler Gears

5-11. INSTALLING ADAPTER ASSEMBLY AND BEARING CAPS. With case assembly still positioned with open end up, proceed as follows (see figure 5-10):

1. Temporarily remove bearing cups (26 and 48) from upper ends of input and output shafts.
2. If removed, press new needle bearing (22) in to bottom in adapter (21) using suitable drift.
3. Position gasket (23) on mounting face of case assembly for adapter. Install adapter (21) on case assembly (71), over input and output shafts and engaging end of idler gear in needle bearing (22) in adapter.

4. Attach adapter (21) with six bolts (19), two bolts (18), eight lock washers (20) and eight nuts (17). Torque to 10-12 lb-ft (13.6-16.3 Nm).

5. Press new oil seal (15) into circular cap (12). Installed seal shall be positioned as shown in figure 5-11.

6. Determine thickness of shims (16) required to properly preload roller bearings under square cap (13) and circular cap (12):

- a. Install bearing cups (26 and 48) (temporarily removed in step 1) in adapter, on bearing cones. Press down firmly by hand to seat on bearings.

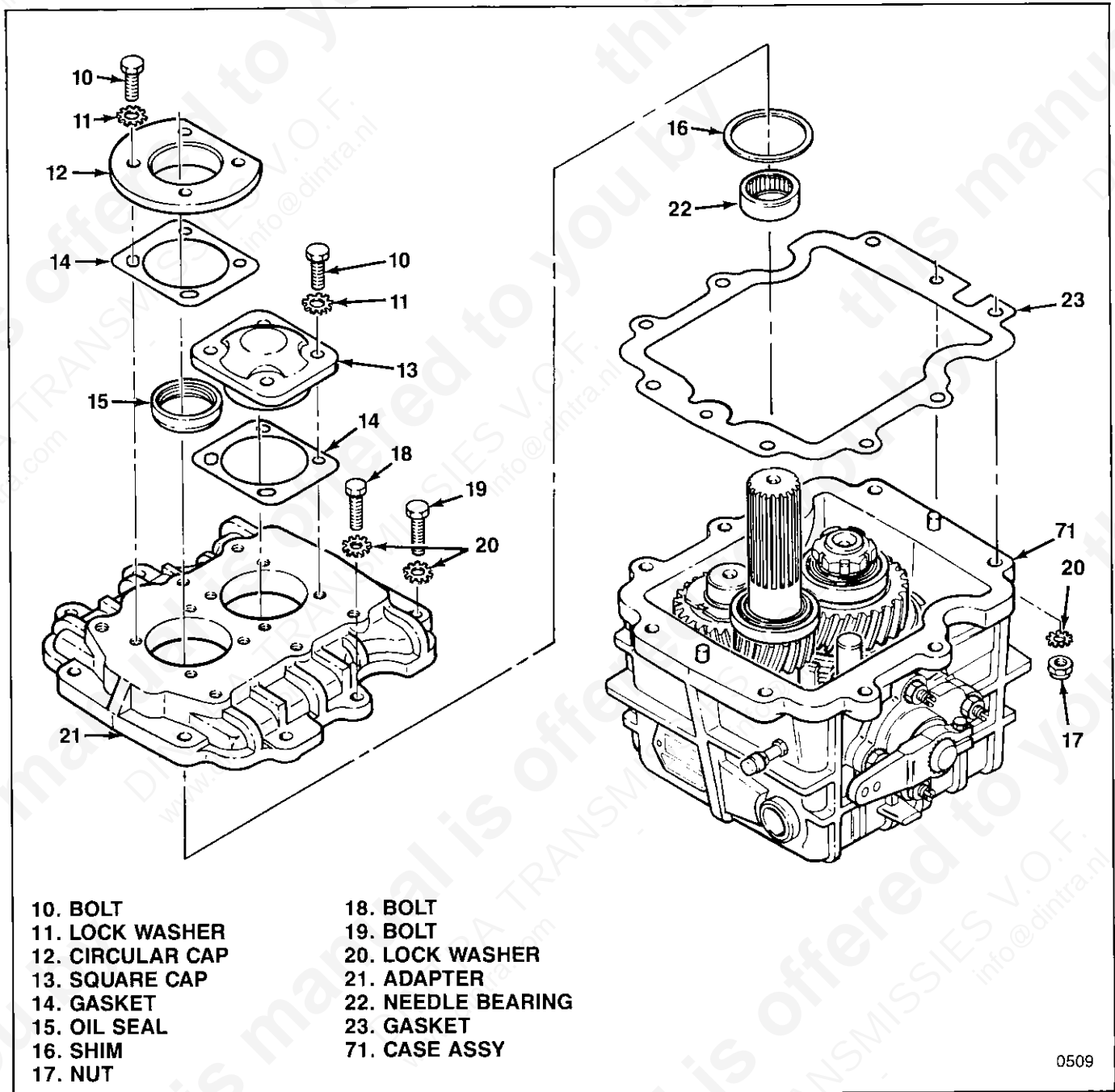

Figure 5-10. Bearing Caps and Adapter Assembly

b. Position two gaskets (14) on adapter, one at each cover position.

c. At each cap and bearing cup take measurements A and B as shown in figure 5-11 using depth micrometer.

NOTE: Figure 5-11 shows circular cap (12) but is typical for both caps. Take separate measurements and calculate shim thickness for both caps.

d. Calculate thickness T of shims (16) required at each cap as follows:

$$T = B - A + 0.001 \text{ in inches, or}$$

$$T = B - A + 0.03 \text{ in mm}$$

7. Select and install shims (16) of thickness determined at step 6 for each cap (12 and 13).

8. Install caps (12 and 13) and attach with eight lock washers (11) and eight bolts (10). Torque bolts to 10-12 lb-ft (13.6-16.3 Nm).

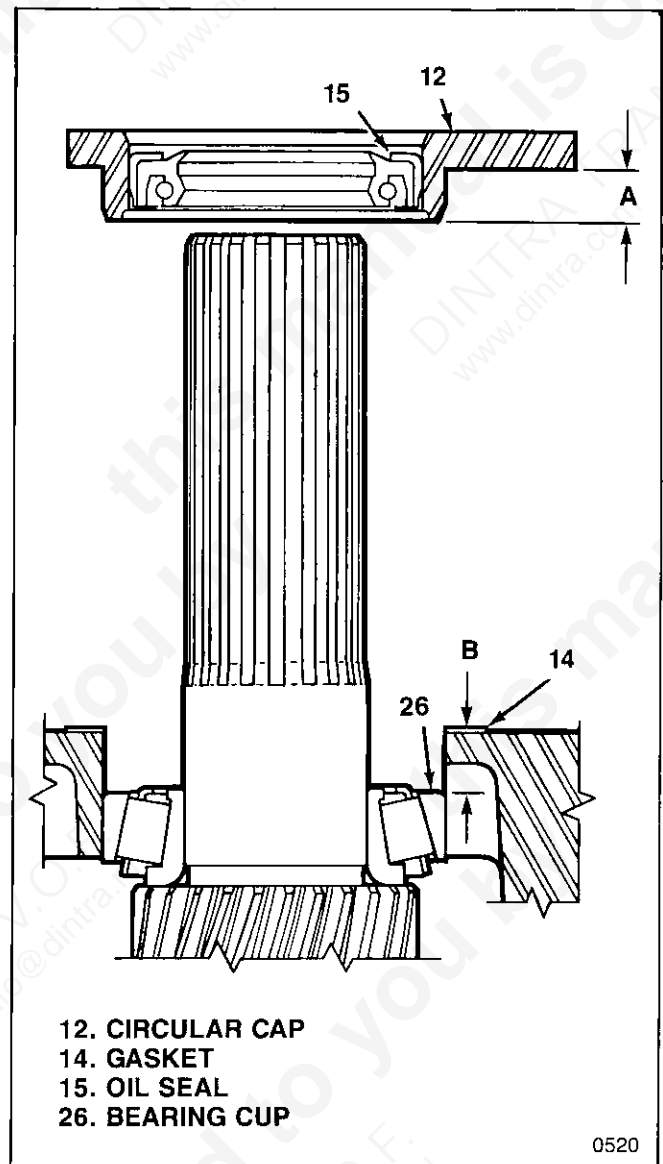

Figure 5-11. Bearing Cap Shim Measurements

5-12. INSTALL EXTERNAL COMPONENTS.

Complete transmission assembly by installing external components as follows (see figure 5-12):

1. If used and if removed, install cooler opening cover (8) with gasket (9) and attach with four bolts (7). Torque bolts to 10-12 lb-ft (13.6-16.3 Nm).

2. Lubricate o-ring (6) and install on output shaft, past threads and up to spline.

3. Install output flange (5), washer (4) and nut (3). Holding output flange with coupling wrench T-504, torque nut to 42-50 lb-ft (57-68 Nm).

4. Install dipstick (2) and drain plug (1). Torque drain plug to 20-25 lb-ft (27-34 Nm).

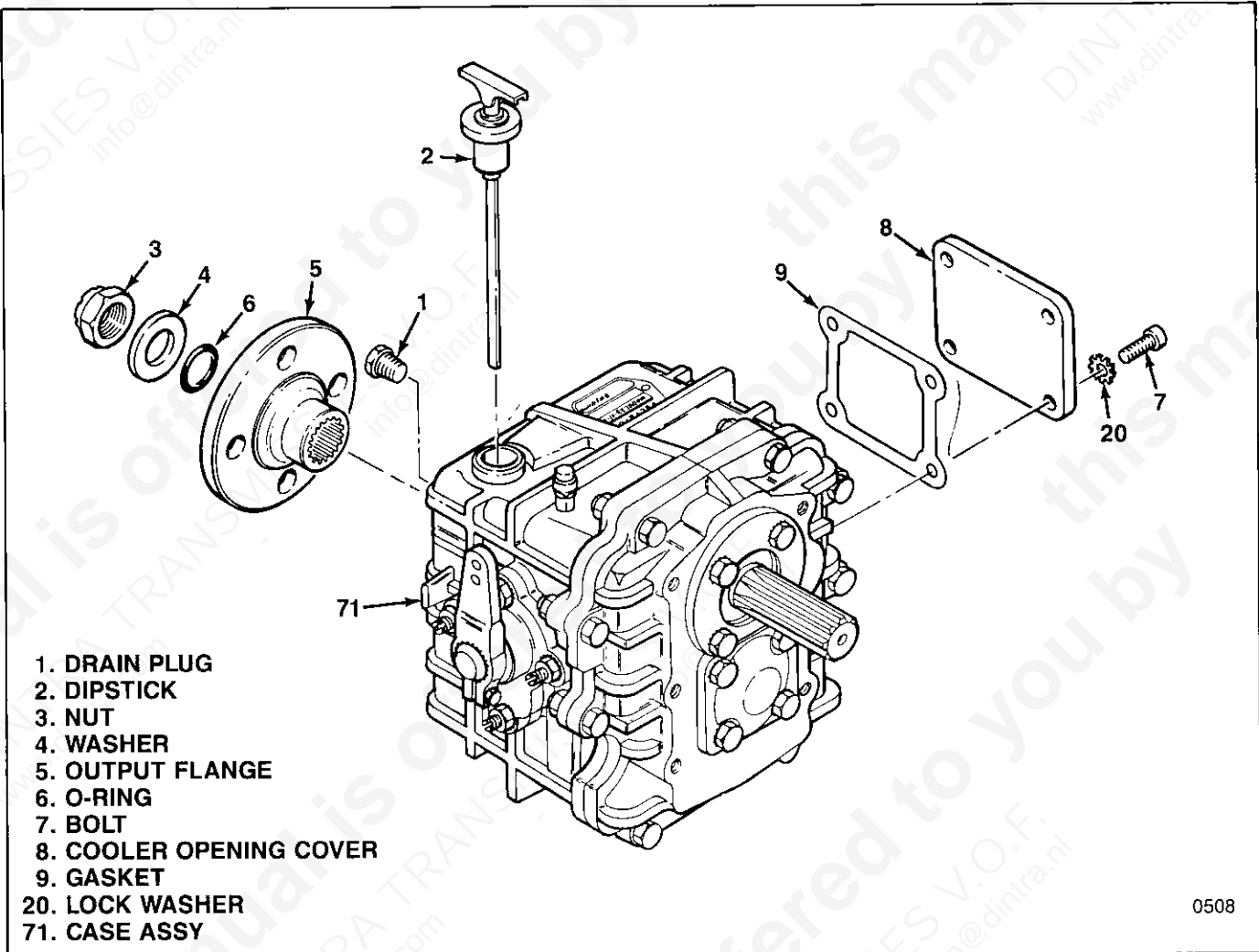

0508

Figure 5-12. External Components

Table 5-1. Torque Values

PART (INDEX NO.)	TORQUE IN LB-FT	TORQUE IN Nm
Drain plug (1)	20-25	27-34
Nut (3)	42-50	60-68
Bolt (7)	10-12	13.6-16.3
Bolt (10)	10-12	13.6-16.3
Nut (17)	10-12	13.6-16.3
Bolt (29)	3.5-4.5	4.7-6.1
Nut (32)	7-9	9-12
Lock nut (45)	42-50	60-68

Section P Parts Contents

FIGURE NO.	DESCRIPTION	TRANSMISSION APPLICATION
P-1	Transmission Assembly	2301-000-001
P-1	Transmission Assembly	2301-000-002
P-1	Transmission Assembly	2301-000-003
P-1	Transmission Assembly	2301-000-004

P-1. INTRODUCTION.

P-2. This section lists, describes and illustrates replacement parts for the Borg-Warner Series 500 Velvet Drive® marine transmission. The exploded view illustration has a corresponding parts list. Index numbers are used to key each part in the exploded views to the parts list and service instructions in preceding sections of this manual.

P-3. The PART NUMBER column in the parts list gives the part number which can be used to order replacement parts. More than one part number is listed for some index numbers. For shims, select as required to meet the assembly requirements specified in Section 5. For other parts, read the description column to determine part applicability.

P-4. The DESCRIPTION column gives the part nomenclature used, not only in the list but also in the service instructions.

P-5. The QTY column designates the number of parts used at the location defined by the index number. The letter symbols AR may be used in this column to designate parts used As Required. This is used for selective fit parts, determined as specified in Assembly, Section 5.

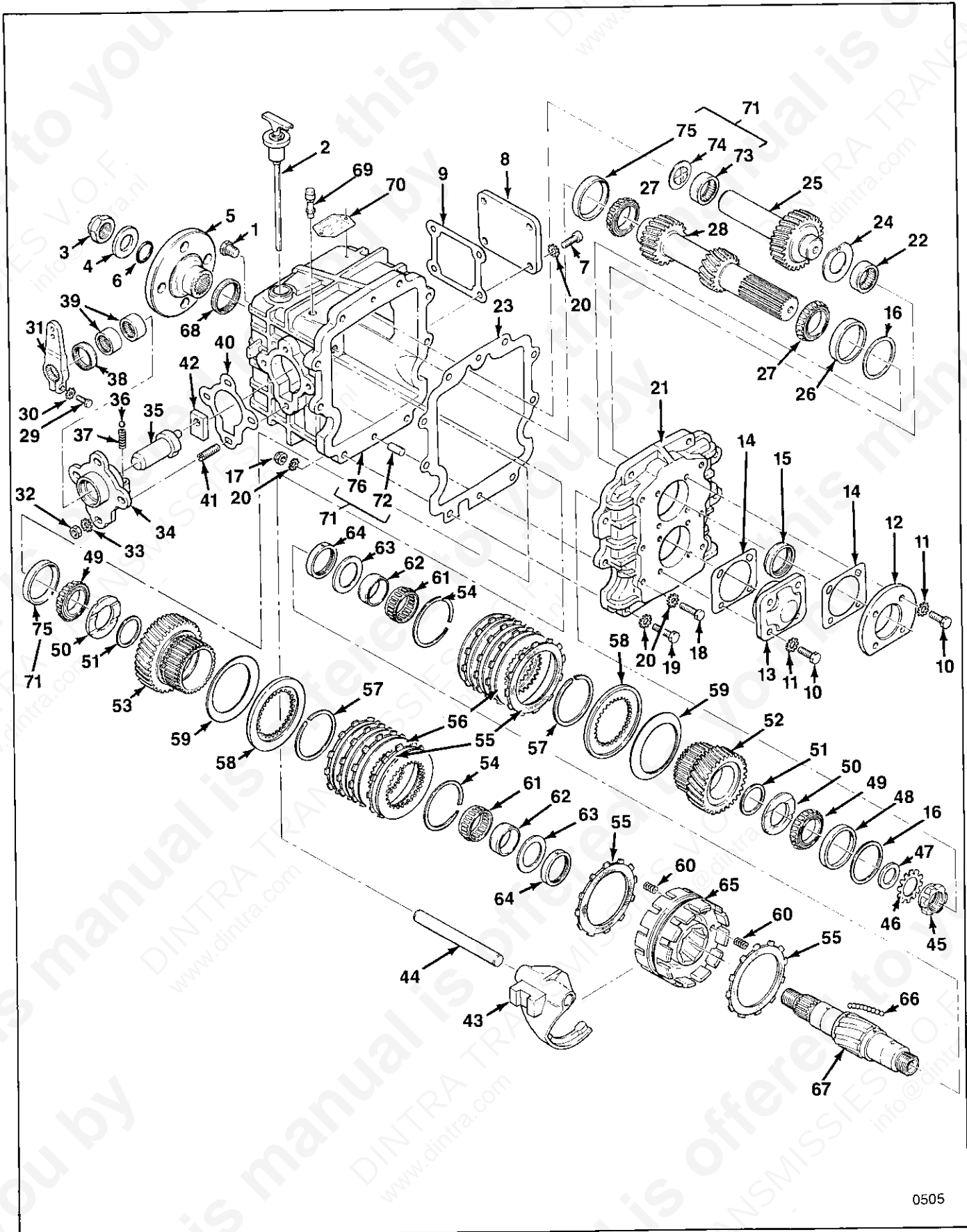

Figure P-1. Transmission Assembly

PARTS LIST FOR FIGURE P-1

INDEX NO.	PART NUMBER	DESCRIPTION	QTY
Fig P-1	2301-000-001	TRANSMISSION ASSY, S500 Marine 1.48:1 ratio	1
	2301-000-002	TRANSMISSION ASSY, S500 Marine, 2.05:1 ratio	1
	2301-000-003	TRANSMISSION ASSY, S500 Marine, 2.53:1 ratio	1
	2301-000-004	TRANSMISSION ASSY, S500 Marine, 2.94:1 ratio	1
1	1000-052-042	• PLUG, Drain	1
2	1006-559-001	• DIPSTICK	1
3	1000-149-010	• NUT	1
4	1000-047-010	• WASHER	1
5	1000-031-033	• FLANGE, Output	1
6	1000-141-476	• O-RING	1
7	1000-183-093	• SCREW, Socket head cap	1
8	2301-039-002	• COVER, Cooler opening	4
9	2301-045-004	• GASKET	1
10	11501872	• BOLT, M8-1.25 x 20	1
11	138485	• WASHER, Tooth lock, M8	8
12	2301-027-001	• CAP, Circular	8
13	2301-027-002	• CAP, Square	1
14	2301-045-001	• GASKET	1
15	1000-044-064	• SEAL, Oil	2
16	1000-037-068	• SHIM, 0.305 mm (0.0120 in.) thick	1
	1000-037-069	• SHIM, 0.330 mm (0.0130 in.) thick	AR
	1000-037-070	• SHIM, 0.356 mm (0.0140 in.) thick	AR
	1000-037-071	• SHIM, 0.381 mm (0.0150 in.) thick	AR
	1000-037-072	• SHIM, 0.406 mm (0.0160 in.) thick	AR
	1000-037-073	• SHIM, 0.432 mm (0.0170 in.) thick	AR
	1000-037-074	• SHIM, 0.457 mm (0.0180 in.) thick	AR
	1000-037-075	• SHIM, 0.483 mm (0.0190 in.) thick	AR
	1000-037-076	• SHIM, 0.508 mm (0.0200 in.) thick	AR
	1000-037-077	• SHIM, 0.533 mm (0.0210 in.) thick	AR
	1000-037-078	• SHIM, 0.559 mm (0.0220 in.) thick	AR
	1000-037-079	• SHIM, 0.584 mm (0.0230 in.) thick	AR
17	11505919	• NUT, M8-1.25	AR
18	11504337	• BOLT, M8-1.25 x 30	8
19	11504331	• BOLT, M8-1.25 x 35	2
20	138485	• WASHER, Tooth lock, M8	6
21	2301-172-001	• ADAPTER	12
22	1000-132-056	• BEARING, Needle	1
23	2301-045-003	• GASKET	1
24	1000-193-015	• WASHER, Thrust	1
25	2301-084-001	• GEAR, Idler	1
26	1000-133-054	• CUP, Bearing	1
27	1000-133-047	• CONE, Bearing	1
28	2301-085-001	• GEAR, Input shaft (Transmission 2301-000-001)	2
			1

PARTS LIST FOR FIGURE P-1 (CONT)

INDEX NO.	PART NUMBER	DESCRIPTION	QTY
	2301-085-002	• GEAR, Input shaft (Transmission 2301-000-002)	1
	2301-085-003	• GEAR, Input shaft (Transmission 2301-000-003)	1
28	2301-085-004	• GEAR, Input shaft (Transmission 2301-000-004)	1
29	1000-183-091	• BOLT	1
30	138479	• WASHER, Tooth lock, 5M7	1
31	2301-098-001	• LEVER, Shift	1
32	11505916	• NUT, M6-1.0	4
33	121753	• WASHER, Tooth lock, M6	4
34	2301-097-001	• HOUSING, Shift	1
35	2301-122-002	• SHAFT, Shifting	1
36	147485	• BALL, Steel, 1/4 in.	1
37	2301-156-002	• SPRING, Poppet	1
38	1000-044-063	• SEAL, Oil	1
39	1000-132-054	• BEARING, Needle	2
40	2301-045-002	• GASKET	1
41	1000-146-012	• STUD	4
42	2301-193-001	• BLOCK, Thrust	1
43	2301-096-001	• FORK, Shift	1
44	2301-122-001	• RAIL, Shift	1
45	127707	• NUT, Lock, M22-1.0	1
46	127684	• WASHER, Lock	1
47	1000-053-025	• SPACER, Bearing	1
48	1000-133-054	• CUP, Bearing	1
49	1000-133-047	• CONE, Bearing	2
50	1000-193-017	• WASHER, Thrust	2
51	1000-037-042	• SHIM, 0.762 mm (0.0300 in.) thick	AR
	1000-037-043	• SHIM, 0.508 mm (0.0200 in.) thick	AR
	1000-037-044	• SHIM, 0.254 mm (0.0100 in.) thick	AR
	1000-037-045	• SHIM, 0.127 mm (0.0050 in.) thick	AR
	1000-037-046	• SHIM, 0.051 mm (0.0020 in.) thick	AR
52	2301-080-002	• GEAR, Reverse	1
53	2301-080-001	• GEAR, Output (Transmission 2301-000-001)	1
	2301-080-003	• GEAR, Output (Transmission 2301-000-002)	1
	2301-080-004	• GEAR, Output (Transmission 2301-000-003)	1
	2301-080-005	• GEAR, Output (Transmission 2301-000-004)	1
54	1000-139-066	• RING, Snap	2
55	2301-666-001	• PLATE, Clutch	10
56	2301-166-001	• PLATE, Clutch	8
57	1000-139-065	• RING, Snap	2
58	2301-062-002	• PLATE, Clutch backup	2
59	2301-156-005	• SPRING, Disc	2

PARTS LIST FOR FIGURE P-1 (CONT)

INDEX NO.	PART NUMBER	DESCRIPTION	QTY
60	2301-156-004	• SPRING	2
61	1000-132-053	• BEARING, Needle	2
62	1000-018-015	• RING, Inner bearing	2
63	1000-193-016	• WASHER, Thrust	2
64	2301-053-001	• SPACER	2
65	2301-055-001	• COLLAR, Shift	1
66	1000-109-003	• BALL, Steel, 5 mm	64
67	2301-171-001	• SHAFT, Output	1
68	1000-044-062	• SEAL, Oil	1
69	A4740G	• BREATHER	1
70	2301-199-001	• TAG, Identification (Transmission 2301-000-001)	1
	2301-199-002	• TAG, Identification (Transmission 2301-000-002)	1
	2301-199-003	• TAG, Identification (Transmission 2301-000-003)	1
	2301-199-004	• TAG, Identification (Transmission 2301-000-004)	1
71	2301-565-002	• • CASE ASSY, Complete	1
72	1000-043-029	• • PIN, Dowel	2
73	1000-133-046	• • BEARING, Needle	1
74	1000-193-018	• • WASHER, Thrust	1
75	1000-133-054	• • CUP, Bearing	2
76	2301-565-002	• • CASE, MAGNET & BAFFLE ASSY	1

Section T Special Tools

This section lists, describes and illustrates special tools required to disassemble and assemble the Series 500 marine transmission. Use of these tools is specified in Sections 3 and 5 of the manual. Equivalent tools may be used provided they perform the same function as the tool specified. Failure to use the proper special tool could result in damage to the transmission. The tools listed are available from R.G. Smith Enterprises, 1265 Colfax Ave., Kettering, OH 45419.

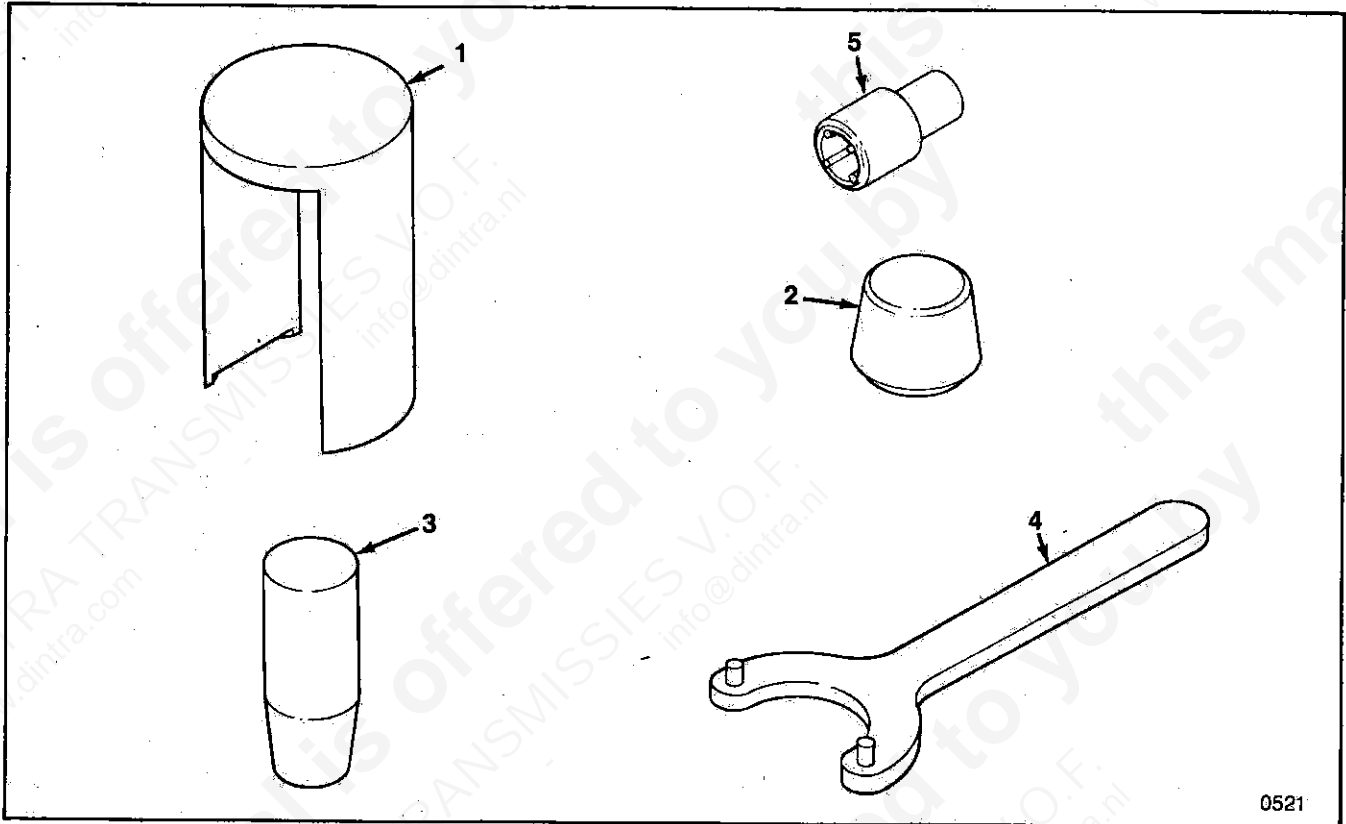

0521

Figure T-1. Special Tools

FIG. T-1 INDEX NO.	TOOL NUMBER	TOOL NAME	APPLICATION
1	T-501	Compression Tool	Compress disc spring when removing or installing snap ring on gear
2	T-502	Expander	Expand snap ring to install on gear
3	T-503	Bearing Drift	Press bearing cones onto shafts
4	T-504	Coupling Wrench	Hold coupling flange when removing or installing nuts on output shaft
5	T-505	Socket	Remove and install output shaft lock nut



BorgWarner Marine & Industrial Transmissions

**Borg-Warner
Automotive
Diversified
Transmission
Products Corporation**

**Marine &
Industrial
Transmissions**

**5401
Kilgore
Avenue**

**Muncie
Indiana
47304**

**Telephone
317 286 6316
Telex
27 491
Fax
317 286 6891**

**Borg-Warner
Automotive
Diversified
Transmission
Products Corporation**

**Marine &
Industrial
Transmissions**

**Kenfig
Industrial Estate
Margam Nr.
Port Talbot**

**West Glamorgan
SA13 2PG
United Kingdom**

**Telephone
656 741001
Telex
85149861
Fax
656 747262**